

The Cloud is not an option

# Infrables

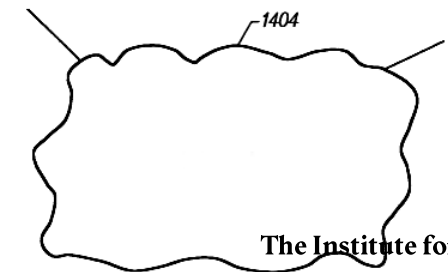

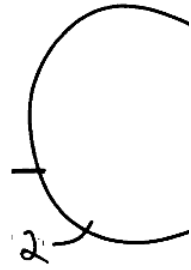
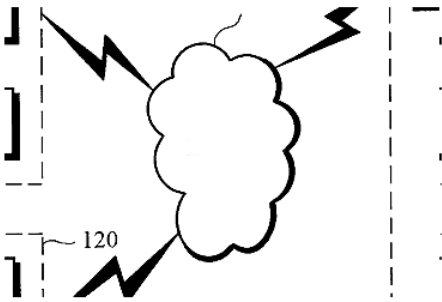
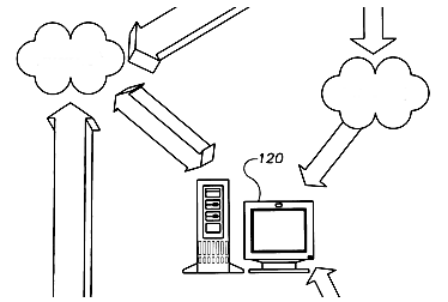
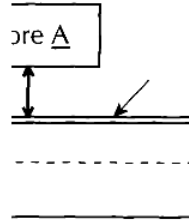
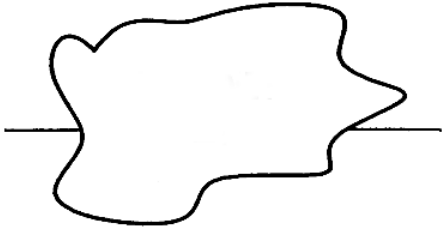
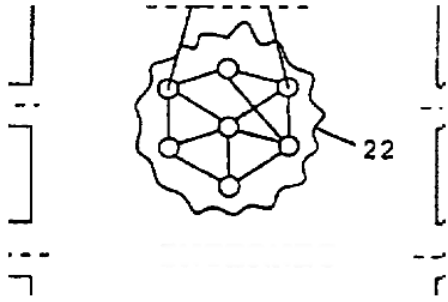
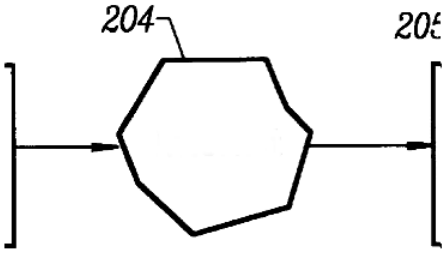
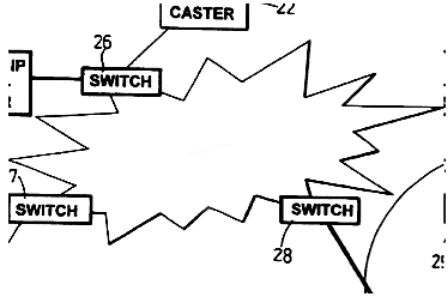
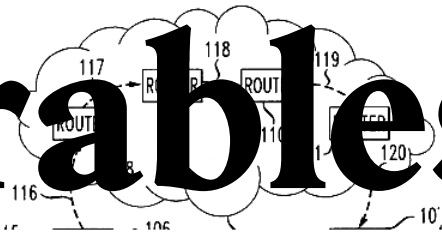

# Infrables

Infrables make negative use-cases and un-fixing bug reports as a solidary praxis. They are articulations of what extractive digital infrastructures are, and what they are doing. What infrables can we tell to take-down Big Tech narratives and undo their violences? Generated through narrative and extra-narrative accounts, infrables identify oppressive infrastructures or tools, but they also make space for other technological attitudes.

How can we follow and understand infrastructural shifts through shared experiences? To what extent do individual experiences stand for a larger whole? What happens when you share, retell, adapt, rewrite someone else's experiences?

This booklet combines infrastructural anecdotes and infrables collected in different situations; you are welcome to add your own or use ones from the collection to generate stories. Please be aware that in the interest of the project, we have decided not to give individual credit to any of them and that others are invited to re-use and remix these anecdotes and infrables with care.

## **Part 1: Infrastructural anecdotes**

1. Bring an instrument. Maybe you find yourself in a room with a guitar. Or some pots and pans or any other set of objects that can make variable noise.
2. Pick a few anecdotes from the collection and read them out loud. One or more listeners accompany the readings with dramatic sound effects.
3. Once the reading is done, work in small groups and tell each other a story or anecdote of an experience involving a digital infrastructure. Take 10-20 minutes to transcribe; give each anecdote a title
4. Pick a few anecdotes from the new collection and read them out loud. One or more listeners might accompany the readings with dramatic sound effects.

## **Part 2: From anecdote to infrable**

1. Form groups of 3-5 people.
2. Each group picks an anecdote. You can also mix several anecdotes.
3. Gather on an etherpad page if remote, or meet around the table if your infrable-session is IRL.
4. Choose some elements, and a format (see below).
5. Re-write/change/re-tell the infrastructural anecdote into an infrable together.

6. Pick several anecdotes from the collection of anecdotes and read them out loud.  
One or more listeners accompany the readings with dramatic sound effects.

## **Infrabling elements** ✨

- Make the intention (instead of the "moral") of the story explicit: what is the intention for the "public interest"?
- Introduce a maxim, "concise expression" or motto
- Introduce fictional agents, such as talking plants, inanimate objects or other creatures (e.g.: the tortoise and the hare, grasshopper and the ant, etc.)
- Make space for natural phenomena, machinic agencies, other animacies
- Scale the timespace of the story
- Infrastromorphise (instead of antropomorphise) agents: attribute infrastructural characteristics, motivation or behavior to inanimate objects, animals, or natural phenomena
- Use rhyme, rhythm and repetition to rewrite/retell the anecdote
- ...

## **Formats**

- A drawing
- A shared BigBlueButton whiteboard
- Some pad writing
- A spoken story
- A song
- A poem
- A fiction
- A slogan/T-Shirt
- ...

## Colophon

These infrastructural anecdotes were made at workshops, meetings and other moments organised by Varia, Tangible Cloud and TITiPI. They are on purpose not credited because of their collective, nebulous, blurry authorship. Thank you to anyone who contributed, and to the organisers of the various situations that brought people together. These infrables are here to be reworked and retold.

Booklet produced at [Tangible Cloud](#), Brussels, May 2022. The infrable exercises were developed with [Varia](#) (Manetta Berends, Cristina Cochior); booklet laid out in [wiki-to-pdf](#) using [Adelphe](#) designed by Eugénie Bidaut; cover image after Noah Veltman: [What Shape is the Internet?](#)

Download as a pdf: <https://titipi.org/pub/Infrables.pdf>

Copyleft with a difference: Collective Conditions for Re-Use (cc4r)  
<https://constantvzw.org/wefts/cc4r.en.html>.

*May 2022*

Anecdotes collected during Tangible Cloud, Brussels, 18 May 2022

## **I did it my way**

Back in 2019 I didn't have a smartphone. Firstly because I considered it an unnecessary expensive, but also because I didn't want to be constantly bothered with work. Which I think are 2 good enough reasons. In May that year, I travelled to New York for a presentation. Not having a smartphone had always meant extra organisation, as it came to make me realise how much information vanished from the public space since having a smartphone was considered the norm. So at that point I knew that I couldn't rely anymore on printed transportation schedules, maps of the neighbourhood at the metro exits or in the bus stops, etc... The day before I left, I printed out a Googlemaps screenshot with the address to the AirBnB and the list of steps to get there from the airport. Everything went smoothly and around 21pm local time I arrived at the Airbnb address. It looked extremely different from the picture I had. I rang the doorbell and heard some noise to which I replied: Come down David, I'm here! The door opened, and I had no clue who the person was. I told him confused that his house was at the address of the airbnb I had booked but he replied this was no airbnb. I showed him my paper Googlemaps and my printed airbnb documents. He looked at them briefly and told me that I was currently in Brooklyn and needed to be at the same address in the Queens. I had a mini phone book with my best friends phone numbers in case of emergency but I couldn't use it because, unlike my European friends' smartphones, my Nokia 3310 was not compatible with the US phone network. From my travel I couldn't remember having seen any map anywhere nor phone cabin. I was lucky enough that the man accepted to call me a taxi who was navigating using his smartphone.

## **Get with the times little lady**

When the elementary school of my kids switched to Google services, both my kids suddenly had a Gmail address, were working on Chrome books and watching YouTube videos during their breaks. When I complained about this, sharing the concerns I had with such sudden surrender to Google with the director of the school, I was told to "get with the times". I tried sending links to articles discussing the many issues there were with Google services from surveillance to being exposed to YouTube unsupervised, and building dependence on these services at such a young age. A teacher tried to explain the benefits and ease of use of Google Docs to me, the blessings of Gmail's generous free storage and that it is really not hard to learn how to use these tech tools, all my hope for a turn of events evaporated. I was clearly seen as anti-tech, a luddite or simply old-fashioned. I did not give up yet, complained some more and was promised a meeting

with even higher management, but never got to speak to anyone, my kids still have Gmail addresses.

## **Le droit de se perdre**

2010-11: j'étais étudiant à l'université. L'Iphone venait juste de sortir. On avait de simple GSM, avec des forfaits téléphonique assez serrés. On se débrouillais pour se repérer et se délayer dans la ville. Je travaillais comme livreur chez Pizzahut. Les livreurs les plus expérimentés prenaient les nouveaux sous leurs ailes. Ils nous indiquaient quels itinéraires emprunter: les plus rapides, mais aussi les plus sympas. C'était stressant: il fallait mémoriser d'avance et se débrouiller quand on ne trouvait pas l'adresse. Quand on était perdu, on appelait le restaurant et quelqu'un faisait le co-pilote. On utilisait des cartes papiers, on s'arrêtait aux arrêts de bus. C'était une connaissance empirique, pas juste schématique. Il y avait une sorte de parrainage, de solidarité. Ils nous donnaient aussi des conseils pour éviter la monotonie. On qualifiait l'espace urbain.

2014: Les forfaits ont gonflés; tous les livreurs ont progressivement acquis des smartphones. Désormais, on utilise pour se guider celui-ci à travers maps avec les écouteurs, guidés par la voix de synthèse. La dimension qualitative de l'espace est ignorée par l'application. Il n'y a plus qu'à obéir; ça semble rassurant. C'est devenu un peu plus personnel, mais moins droit à l'erreur: on est équipé d'un appareil qui, lui, n'en fait pas. La durée tolérée d'une course diminue. On est plus supposé se perdre.

## **It is hard to resist**

I always resisted to create a Fb account. For different reason. Among other, political reasons. And I'm not a social person, in terms of social networks. I'm not interested. I don't like staying in touch for the sake of staying in touch. After more than 10 years without Fb, it was still mysterious and almost exhilarating look over one's shoulder and try to understand the kind of interaction.

Then my daughter went to school and I received a small brief asking for authorization to publish photos of the class on the Fb account of the school. At first, I said yes, but ask to obfuscate her face. But she was always alone with a smiley face. The next year, I Gave up a bit more and we authorised publications without smileys. But still, we had no way to easily watch the pictures because of no Fb account.

I would have been to much effort to ask the school and the parents to change platform, to change their habits. We felt we had no lever. I asked my mother in law if I could use her account. I dedicated a web browser only for that. It is strange because I fell like I'm intruding her space. I fear to «like» something by mistake, or to read a message I'm not suppose to.

In the end, it would have been easier just to create an account.

## **Cadavre Numérique (Digital Corpse)**

Le smartphone tombe mais ne se même brise pas. Le server, celui-ci n'était en fait pas connecter au reste du zepplin. La prise qui s'est toujours prise pour un serpent était au milieu de cable impossible à différencier.

J'ai mis ma main dans le sac de noeud, dans son code à ne plus savoir les slaves ou les masters. Les masters en clouds ne savait pas différencier les infrastructures des vrais nuages, des vrais navigateur, des vrais surffers, des vrais corbeilles, tout se dématérialisait petit à petit pour devenir des NFT pour toujours. Le smartphone ne se brise toujours pas.

## **Detective Facture**

Tous les ans on doit faire un bilan comptable pour l'entreprise. Je m'exécute et me rend compte qu'il y a une dépense sans facture, pour une assez grosse somme, genre 200€. La facture est introuvable, le comptable insiste ; on a besoin de cette facture. Il se trouve que cette année là, plusieurs employé.e.s ont quitté l'entreprise, et comme je ne me souvient pas de cette dépense, j'imagine que ça doit être l'un d'entre eux qui l'avait effectué. Je regarde sur l'appli du compte bancaire qui crope tout les noms des transactions et je retrouve cette dépense puis le nom du site internet qui y est lié en cherchant sur google. C'est ma première piste de l'enquête.

C'est un site d'outils et je comprend que je vais pouvoir retrouver la facture si je retrouve les identifiants de la personne qui a fait la transaction. Je commence alors à tester toutes les adresses mails des employé.e.s partis dans l'année. Il y en a effectivement une qui est liée à un compte chez eux. C'est celle de Charlotte. Le truc c'est qu'une que les employés sont partis ont avant supprimé leur adresses mails. Comment acceder à un compte dont l'adresse email n'existe plus ? Je me retrouve alors obligé de recréer l'adresse mail de Charlotte vuq ue j'ai accès au nom de domaine, puis de faire la manip "j'ai oublié mon mot de passe", pour recevoir le mot de passe temporaire et enfin accéder au compte en ligne et récupérer la facture. J'ai du me faire passer pour Charlotte, je suis pas sur que ce soit légal. Je me suis rendu compte du pouvoir en tant qu'employeur de réécrire les mots de passe de tout le monde.

## **Serigraphic Non Solutions**

Mon copain m'avais offert un bon d'achat pour des cadres de sérigraphie. J'achète les cadres genre 4 ans plus tard. Je voulais acheter des neufs en alu pour la performance. Je veux pas passer par amazon.



Je regarde donc où je peux acheter sur place à Bruxelles, mais c'est trop cher. Je trouve des revendeurs en France. Je commande auprès d'eux. Ils s'appellent Serigraphics Solutions. Au bout de 2-3 jours je devais les recevoir via le transporteur DPD. Je regarde où ça en est. Je sais pas pourquoi mais je trouve qu'il y a un truc qui cloche.

Je regarde sur le site des vendeurs et je vois que l'entreprise est en liquidation judiciaire et qu'ils ne peuvent pas répondre de suite. Donc j'écris un mail pour savoir si c'est envoyé. Je ne savais pas si le colis avait été remis. Ils me disent que c'est bien parti dans la dernière livraison. Du coup je suis rassurée et je me sens chanceuse, peut être la dernière à pouvoir recevoir la commande de cette boîte. 2 jours plus tard le colis n'avance toujours pas sur le site du livreur et stagne dans un centre de tri dans le Jura. Je regarde donc de nouveau le site du vendeur et ça y est Serigraphie Solution n'existe plus quand j'essaie de les contacter il y a juste un message d'erreur.

J'appelle donc les livreurs qui me disent que ça va arriver. Mais au bout de quelques jours le colis commence à faire le chemin inverse ! Le colis est en retour à l'expéditeur ! J'oscille entre euphorie où je me sens trop chanceuse et moment de déprime. Ils me disent qu'il y a eu une demande de retour de colis mais c'est impossible puisque l'entreprise n'existe pas.

ça a duré pendant des mois au téléphone, où j'étais dans une boucle et on me répondait : "Il faut contacter l'expéditeur", "oui mais il existe plus", "oui je comprend mais il faut contacter l'expéditeur".

J'ai finis par contacter le liquidateur juridique pour faire une reconnaissance de créance, et il m'a renvoyé vers le transporteur. On une sensation de contrôle via le suivi étape par étape en ligne mais bon, au final tu ne contrôles rien.

## **Say Cheese**

When we were going from Hong Kong to China, we had to pass through customs with packed bags that included some souvenir Dutch cheese (Gouda). We hadn't kept it in the proper wrapping nor refrigeration (it was in plastic in 30+ degree heat for about 2 weeks. When we arrived at Customs, some security guards called us over and pointed out the mass they had detected in their x-ray scanner. We didn't speak much Mandarin, and they didn't speak much English, so we gestured back and forth to indicate that it was cheese by inviting the officers to smell it. They opened it up, took one smell and very quickly hurried us through without any more questions.

## **Past the Point of No Return**

I was living in Japan and had decided to take an impromptu holiday to New York City as flights were cheap. The thing was, in order to come back into Japan on my visa, I needed

a re-entry permit. To get this, you had to go to a city office and have your passport stamped in person. I kind of forgot about it until the day before my flight, when in a panic I looked up where my nearest city office was. It turned out that as a cost-cutting measure the Tokyo Metropolitan Government had closed all but one location, which was on an artificial island in Tokyo Bay. I went there straight away, and crossed a bridge (the only one to access the island) to find a large, 8-storey government building. The lower 4 floors were for processing permits, licences and visas and the top 4 floors were a detention centre. I hadn't yet paid my city taxes so I was a little terrified that I would be sent upstairs. I took a ticket (number 467 or some ridiculously large number) and waited. The office closed at 5pm, and by the time it was 4:45pm they were only up to number 300. I started to worry and decided I should try to get served as soon as possible. A clerk called out number 301, and nobody answered. I saw my chance, went to the counter and said I had lost my ticket. I got my permit, got the hell off the island and escaped.

## **Jerome anti-covid**

Pendant le lockdown en France, au moment où il était seulement possible de se promener à 500m de chez soi, un ami, Jérôme, a créé un script permettant de générer des attestations avec une adresse à moins de 500m du point où on se trouve, à partir des coordonnées gsp. Un pdf d'autorisation de sortie était donc généré, quelque soit l'endroit où je me trouvais, à condition qu'il y ait des habitations autour.

[EN] During the french lockdown, while it was only possible to go as far as 500m from your house, a friend, Jerome, created a script allowing us to generate autorisations based on your GPS current location with a "home address" within 500m. The generated PDF allowed me to go anywhere as long as there was houses less than 500m away.

## **Belgique vs Linux**

En Belgique, un certain nombre de services publics sont accessibles via la carte d'identité électronique (e-ID), mais à chaque mise-à-jour, il y a un temps avant que ça -e sur Linux, selon les navigateurs etc. Un moment, à force de ténacité, j'ai trouvé un technicien du service fédéral qui avait à coeur de rendre e-ID disponible sur Linux et firefox. A force d'échanges, j'ai eu son adresse email direct, tout allait bien jusqu'au moment où il a changé de service. Je dois donc maintenant emprunter un ordinateur Windows pour mes démarches administratives.

[EN] In Belgium, many public services are accessible via your digital ID card (e-ID), but for each updates, there are issues with linux and certain browsers. After a while, and with some tenacity, I was able to reach out to a technician in the federal office who was

eager to make it work for Linux. Everything was fine until he changed of office and now I have to borrow and Windows computer when I have to do administrative tasks.

## **In-door camping**

I was still living in Brussels back then, and this a was a typical bar evening. I had friends visiting, so I was in a very good mood, glowing if I may say. So we go to this bar, when I met a very pretty person, which I happen to bring back home. So we spent the night together, everything is quite pleasant, and we end up chatting about our lives. I told him I happen to have friends now living in a caravan somewhere in the swiss mountains, among other stuffs. He eventually leaves, and I'm now hangover hanging out in the house, so I figure I should check what's going on on my Instagram account. I start scrolling hazily when something catches my attention. It's a very neat looking little add for buying a very pretty \*caravan\*. I scroll down a bit athen BAM another add for buying another even nicer looking caravan. I must say I wasn't following any caravan or camping account of any kind. Last time I went camping I was about 8 and it was definitely not with my consent. I do happen to like walls, and I'm not so sure nature is a friend. So I figured, the only explanation was, the nice little pink photosharing app might have eavesdropped on the conversation. And probably on what did precede the conversation. I started to completely freak out, like my heart literally went down into my shoes. I figured I should throw the phone out right away and go back to my dealer phone phase, which lasted approximately 2 years. But I did not have the strength to give it up. Again. What I did was, delete the app and prey so that all these conversation eventually burns in a hudge warming fire, like the OVH servers did.

## **Covid E-life at university**

So my story takes place at the university. I had to make a presentation for my teachers (4 teachers).

In the first time, I had a one teacher with sound problems. The sound was choppy.

Finaly, I Resolved to send a teams link (official link of the university).

Result: only 2 teacher could connect.

The 3rd person took 35 minute to join us and the last one never came. Probably because she was connected by an other institution in teams software.

Moral: the free software doesn't work well, the proprietary software doesn't.

## **Web knowledge issues**

I'm lucky, I have two stories to tell.

I'm a teacher and I teach some web lessons for students in graphic design. For the lesson, they begin to create some local pages in HTML and CSS on their own computer. During the break, a student send me an email with a link to his website... with the whole local path of his website on his computer as an URL for me to see the website.

Second anecdote : It's also during one of the lesson. I show the website of internet archive to the students – for those who don't know, it's a website which show some copies of website from different times. As I began to type "Youtube", the sites auto-complete with the name of a known pornographic site. The students laugh and I ask them « why » ?

They explain that another teacher has some tabs open in his web browser with his favourites porn pages and all the student can see it as he share his screen in class.

We can ask : does this teacher have a lack of basics about privacy questions or a lack of knowledge of what he do ?

## **Getting a Smart Phone**

I was sort of trying to use, as much as I could, public phones. It was interesting. I had to maintain a local map of the still-existing public phones because obviously, they were disappearing. I could still manage to live without a mobile phone. Then I moved to Spain. I didn't have this knowledge about where phone booths were in this city. That was already a big problem. The second was that people were deciding, using smart phones, where to eat. It was decided over eating, with text messages, where to go. To meet someone implied that you had a telephone.

Interesting, we would go to the house of a friend and it would just have numbers. Unless you knew that the number was 3-B. So normally you would text message to find out the number to ring. So the telephone was deep down in the social habits.

So I bought one. At that time I had a prepaid card because I did not want my name associated with the phone. So it was very expensive to use it to go online and I just didn't do it. Until recently. For some reason it stopped working (the internet) from one day to the next and I just didn't bother to fix it. But I could still use WiFi if I really needed it.

I bought a new FairPhone and now I'm completely in to the system.

## **Theory of Conformity**

I grew tired of these discussions about technology going nowhere

privacy or exploitation, limitations, operate within parameters do it their way, none of these arguments worked with my friends

frustrated about being party pooper, rational discussion

frustrating irony of seeing people discussing Negri over Zoom with their macs. They have the imagination to talk about these theories but not try out another chat program.

## **Commodity Cameraderie**

Another problem, we are caught into discussions about products

My mom has a knitting group . They knit together and during pandemics decided to knit online. They paid for Zoom. When asked why pay for software instead of using something free, she said they didn t work as well as Zoom. With Jitsi if something doesn t work it's the fault of the software, when Zoom doesn t work it is the fault of the user: you should update

Recently I am more trying to make aesthetic argument, using food as an example. Something that is not necessarily efficient. Optimisation conformity efficiency you loose aesthetics Lose any possibility for sthg expressive, personal, local, regional

Something that comes from a tradition like food is a nice example or architecture, furniture, material culture.

*June 2021*

Stories collected during the workshop [Digital Solidarity](#), on-line, June 2021

## **Trying to get vaccinated but failing**

I patiently awaited my turn to get vaccinated, and after many months of being impatient, I was finally old enough. I visited the website through which to register, entered my year of birth and got the message that it was not possible to get vaccinated. Many of my birth year friends did manage to get an appointment. I tried calling and hurray, success. Later it was announced the website of the government had a bug that stayed uncrushed for weeks, leaving many willing people unable to make an online appointment. It has since been crushed.

## **Hanging there**

When I arrived here at Rotterdam I remembered a friend of mine from long ago was living here somewhere. I have shut down my Facebook a few years ago but I had to reopen it cuz I had no other way to get in contact with her. When I did it, I found my profile intact, outdates and it creaped me out, but worst was to see and decide if I should read or not old messages from friend and colleges, job offers, favors and happy birthday's hanging there unanswered. I left as soon as I could.

## **What if I was not fit?**

I remember that every time I wanted to register for a COVID test via the website I would always get options to get tested in random places, often far away from where I live. That was despite the fact that I marked the option that I cannot get there by car. Even though I did not always feel fit to get to the test location, I am a young and able-bodied person. I kept wondering what happens if you are not as fit? Why were there no more options presented? it was different when you registered for a test by phone.

## **Sentimental download**

A best friend from high school passed away many years ago. We both used Xanga as a blog/journal during our high school years, and used the private messaging system essentially to joke at eachother back and forth - empty chats. Xanga messaged me when they were shutting down in probably 2014... or earlier? asking if I wanted to download the text code of my page. I did, and in the bundle was also included my and Stephanie's private correspondences, hidden comments, hidden posts. This is a moment of tension, perhaps grief (two years after her death), but also sentimental.

## **Check-in**

The phone I use is quite old and so I could not download the national tracing app. I therefore could not access some locations as I could not "check in" digitally. This was during the first lockdown, but it seems that since then venues have been told they could not discriminate against people without the app and to offer alternative (paper) check-in processes.

## **Faceless**

In the work that I do the organisation uses Microsoft Teams. In the first meetings we had I didn't want to install the app or program on my laptop, and so I joined straight from browser. It took me some meetings to realize that that was the reason why I couldn't see my colleague's faces, because the software allows you to see other people's faces only if you install the program.

## **A string of spam**

This and last year I've visited both Luxembourg and Germany for projects which during covid brings along a string of tests. I noticed after my visit last summer that my spambox of the old email I filled in at a corporate test center filled up with German spam. (unsurprising, but still sucks). Freedom of movement seems more than ever directly related to how much information you give. Last month public spaces opened up again in both countries but under the conditions of an antigen test. Restaurants etc can be entered but only by providing some spit, sometimes in combination with name, address, phone number and a show of ID.

## **Domestic vulnerability**

Out of curiosity and of enthusiasm, I am running a small chat network from the meter box in my home. It actually is connected to an electricity plug right under my bed, so sometimes when I hover the bedroom and I touch the plug, the whole network goes down. A small form of domestic vulnerability. But anyway, the network runs most of the time.

## **Lost letter**

My flatmate received COVID support during the early months of COVID, since she was unable to work in either of the two jobs she had. She applied for it, unsure about the conditions, even though she was fulfilling the conditions. At some point we received a letter from the government that was unfortunately misplaced & buried under some newspapers we receive from our neighbours when they are done with them. Because she

hadn't seen the letter within 2 weeks and because she hadn't responded she had to give back the entire sum. We assume the reason why the letter wasn't also sent digitally was to check if she was home during this time.

## **Overheated laptop**

During the pandemic my laptop is suffering so much. It is getting a bit old (not even that old), but videoconferencing is so tough on it. I am not a professional participant in video conferences, not being able to use background images, sometimes accidentally logging off because my laptop got overheated.



## *February – May 2021*

Anecdotes collected in the context of Infrastructural Interactions, between February and May 2021

### **The National Number**

I needed to get a covid test for travel, so I could return across the border back to the UK. He said there is no problem we can get you a test and we asked how to pay for it as all over the entrance there were A4s saying no cash and then he said upstairs they will give you a national identity number. A guy gave us a green piece of paper on which a homemade form was printed in french that asked for name address date of birth so we went outside to fill it in.

I saw the doctor and he spoke English. He asked to see my passport, and why I was going to the UK. This part was straightforward, he photographed my passport on his personal phone (it had a family picture on it), which I felt was strange but by this time I just wanted to get my national number. I probably should have asked about it ... it was clearly for logging and I was not asked for a signature. It was super hot, I was getting tired and there were probably some ill people in the rooms and I had only 7mins of battery on my phone so I was ready to comply with anything to get my NN. He gave it to me and he said that's fine, you can book and pay for your test online. The security guy came and got me and lead me to what he called the holding area and it was just a few chairs. He said you can sit here and pay and book for your test, and then have it.

I went on the website and went through all the familiar stages and used my new NN and that went fine. I was then able to select the test centre and the test day and this took me to a payment page which was facilitated to google pay, you could pay with visa mastercard but not paypal or with your linked google account. I paid and put in my creditcard number and I got worried because I only had 4% left and knew I would need to show it at the next stage. So I just used the autofill to put in the creditcard, my name and the email and hit pay. I used my banks authentication so it definitely went through but it came back to the covidtest.be website and it took me back to the vendors website. Nothing downloaded. no PDF, confirmation. I was getting worried and thought I am going to try use my prescription since I now had my nn.

Now there was a new person on the shift, a young student, and her English was very good. She first starts getting my details and is checking them against the information on the QR code. It turns out that the auto-fill has spelled both my email and my name wrong. So I realise this may be the reason I did not get any info about the one I paid for and I am thinking ... shit! She says no worries and corrects until the right info is there and she hands me a blue tube to give to the nurse. She explains that with the free test

you only get a text message but the paid ones have your id number and passport number and a PDF.

She says to me you will need this for getting into the UK. I explain to her that I did buy the test -to travel one and if she could look it up and she ask me to show the transfer on my bankaccount. Now I have 2% left. I go into my banking app, my banking is all on the phone. I put in my security details and there is a last payment of 56 pounds and assume that this is the last payment and should be for the test. I show it to her through the window saying this is definitely it. She says: "that is fine".

Later I realise it was actually a payment for food two days earlier in a supermarket.

## **Paying with Amazon Vouchers**

When we were setting up a research project 'infrastructural interactions' - I think it matters what it was for - we thought it was really important to pay participants in the conversations we were organising but the project it was administrated between two different universities so we ran into many different problems with paying participants. Part of the issue was that it was felt as unethical to pay participants I guess because of fear that it would influence the research results, but another part was that we were not able to pay participants based in the UK because the university had decided this could only be done by giving them Amazon vouchers, we guess this was because it would not set up a financial relation with them, wouldn't be seen as payment and also would not be showing up as a financial dependency but as a gift. Of course this is also in the interests of the participants; they would not have any registered income which would interfere with their benefits or taxes, but we really did not want to spend any project money that is critical about cloud computing on Amazon vouchers, even if we were sympathetic to people not wanting to mess up their benefits. So what we realised is that because the university using these vouchers, they were siphoning public money into Amazon on the one hand but also using Amazon to in a way support tax evasion, to support creative bookkeeping in an attempt to optimize their financial operations in the sense it was easier for them to give out the vouchers than to actually take care of a proper payment of someone who had contributed to project. The other part we can put in here, is that they clearly assumed that the participants were on benefits. It also has to do with ... a big part of it is because of the Universal Credit system, which is how benefits are organised in the UK at the moment, are designed people from making claims. It is highly aggressive towards having any additional payment outside your benefits; you will lose your benefits completely if a payment shows up. UC aggressively discourages people from staying on benefits. It is a system that is micromanaged.

## **Vaccine bro's**

So people doing sexwork were saying to me, "do you have the vax badge on your profile", and then others were asking "have you seen the taglines on grindr", people are labeling themselves as big bear Pfizer, as Moderna otters, some said they saw a profile that was labelled, let me check it was ... yes: "Grindr profile of a "vaccinated top" with the foreboding caption, "It has begun." It's inevitable: the antibody bro is about to become the vaccine bro".

## **Corona 'Help'**

With the first Corona aid, you could get 5,000 euros and there were people who got that. There were also people who took money fraudulently. That's why people had to give it back. Most of the people I know have actually transferred the money back. Because it is not clear at all. And there is so much stress. It's so unclear. You are being criminalised very quickly. People then immediately make a case of fraud. At the beginning it sounded as if it was available to everyone and you had to apply for it very quickly. You only had a certain amount of time to do it. I think it was 10 minutes or so and then the page closed. But the problem is, only if you received a number, you can get to this page, you've been waiting for days until you can get to the webpage. And I also have to confess, I didn't read the small letters, I just saw "I can get money". So they asked "Do you need more money?" and I of course said "Yes!". I wasn't entitled to that much help, because it was only for operating costs. But I didn't read the instructions. I was just trying to get my turn before Berlin said they had no more money. Because after that there was a time when it was stopped, because there was no more money. And now it's like this, you need to pay it back in one go. But it's not clear who pays back or not. And every tax advisor says something different about it. It's the same with friends. But then you are criminalised. As if you did it consciously. I was in such a panic because it was clear that we wouldn't get any money for 4, 5, 6 months, that at first I just clicked, I need money, I need money, I need money. But it's already true, the billions that are paid out to the big companies and what is then made out of these small amounts. It's all pure neo-liberalism.

## **Self-managing a demonstration on Eventbrite**

So normally I try to participate in the 8th of March activities either go to march, or join a demonstration but this year it was not allowed to go out onto the street in groups. So I was looking on-line if there were any activities planned and then on one of the websites that normally has calls for the demos, there was an announcement that the organisers had permission for gathering a hundred people and that you would have to sign up on Eventbrite so that the tickets could be distributed. Actually, it wasn't Eventbrite, but I think for the story it doesn't matter. So I clicked on the link and of course all tickets were

'sold out', like already they were 'sold out', of course. So in the end I joined another activity and ended up on the same square on which these 100 ticketed people were supposed to gather. I realised they had blocked off with tape ten areas for 10 people to gather, and had rented metal barricades - the cattle thing, they had made a circle with these barricades so inside there were these sections for ten people each so it meant that the organisers of the feminist or women's march had self organised this idea of checking who had signed into the Eventbrite, maybe they would have a barcode scanner at the entrance to this zoned off area. But what had happened is ... I had joined a less official feminist bike ride, we were so many we flooded the square so the whole setup crashed - people were crashing through the gates, broke the tape, there was a mess of bikes and people, it was a mess, there was no way the organisers could have kept with their promise of managing their crowd. So the worry about the barcode scanner being put in place, the fact that everyone participating in the official march had given their name, address and email, is really scary and the fantasy of becoming its own police force that the organisers held was really scary -- from the setup you could see they thought they could manage it -- and then the white punk girls just crashed it.

## **Spitting with couriers**

I was traveling - trying to travel to Brussels to see my comrades and I was very anxious. I had ordered the COVID test and downloaded the app. There was a technological hitch and so it arrived two days late. I was anxious about the test not being testable, that it would be a non-viable sample, so I rang the company and they said "It is good to keep the sample as fresh as possible", and so I could book in a courier between 08:00 and 18:00, that would come and take my sample to the lab. But they could not give an exact time. As fresh as possible! They told me to wait until the courier arrived, knocked at the door and to spit into the tube whilst he waited. He arrived at 13h and knocked on the door and he waited while I watched the video, and spit in the tube. Wait, I had to go through the app stages. Open the tube, scan the barcode, watch the video, whilst he was waiting. I then sealed the sample and had to put it in a transparent bag that I handed over to him and at that moment we had eye contact, as I passed him my tube of spit. At that moment I thought: is he my nurse?

## **Senior's web**

We're invited to participate in a large funding project on "Democratic AI", which is managed by a group of people working at a university in The Netherlands. The first meeting I attend to, happens of course in MS-teams. I never used teams before, so I ask the secretary for a separate test, to find out whether it actually works without an institutional account. After meeting the other partners of the consortium, I am invited to contribute to the 45 page application. The secretary of the project sends me a link to a Google drive but I cannot access the drive without signing in. For a moment I doubt

whether to propose the consortium another on-line storage solution, but I don't feel confident enough nor have energy to manage it. Instead I tell the secretary that I don't have a Google account and ask if she can give me access without it. She sends back an email with a link to "seniorenweb" which explains how to make an account without signing up for gmail. When I make a joke about her considering me part of the elderly constituency, she replies: "I am a practical person. Just pick the site with the best explanation." I give in and sign up for a Google account for the first time in my life.

# *Infrables*

## **e-life**



### **The Lion, the bridge and the beekeepers' choice**

The beekeeperz and their beez were going to a convention on an island. It was their annual gathering, and they were all very much looking forward to the meeting and enjoying their yearly Zpelling Bee, where competition waz fierce and there waz preztige to bee won. There were also french zpeaking beekeeperz, who preferred to partake in the dictation competition spoken by beez, an opportunity for keeperz to boast their refined skillz in distinguishing bzzzzs from buzzssss. The convention took place on an island in the middle of a foggy zwamp. Normally, the beez would fly and the keeperz would walk but heavy rainz the night beefore meant the island was zeparated by a rushing creek. The beekeeperz were relieved to discover two bridges that crossed the water, one made of wood, one of plastic. The wooden bridge appeared to bee handmade and well-used, zo much that holez had worn in zeveral planks. This bridge was made by locals, and they always kept extra-planks at both sides of it, beecause they know that it needed maintenance. The plastic bridge, white and shiny, was installed by the corporate lion who came from far away. He was called Leopold the customer service lion, who required

an authentic carezz on the head to perform his role to optimal zatisfaction. However, zometimes Leopold's hunger would emerge and a gentle carezz could beecome a genuine risk to those who bravely touched him. On the other hand, one could feed Leopold and avoid this scary experience altogether.

Four beekeeperz stood in front of the two bridges and had to choose the best way to crozz. The first one said : "I once heard, Buzzzzzfeed wrote a raving review about plastic bridges." They stepped onto the spotless plastic and kindly petted Leopold. After a few confident steps towards the island, their foot slipped on the wet surface and they fell into the creek. "How would you rate this bridge?", said the lion. The second beekeeper said "Plastic bridges have modern design! They are the bees knees!" They gave a hand-full of mince to Leopold who let them pass. But then after two steps, a black swan swam by, bumping the plastic bridge which, being very light, twisted easily and sent the beekeeper falling into the stream. The Lion announced "We appologise for the inconvenience but we are doing all we can to support our customers in this extraordinary situation." A third beekeeper approached the bridge, and zaid "Well, that wooden bridge obviously has bad usability and I just don't have the time to learn how to fix it". Halfway across the plastic bridge, a gust of wind picked up and the beekeeper slipped off to fall into the water, too. The last beekeeper had nothing valuable to offer the lion, and stood in front of the wooden bridge in desperate need of patching. She picked up zome branches and fixed a few wobbly plankz, while crossing and arrived at the island, dry and satisfied with her good work. She helped her colleagzz out of the water. Dripping and exhausted from the swim upstream towards the island, the beekeeperzz and the bees were finally joined for their annual gathering. And, there were heaps of croissantz, hugz and a big relief. Buzzzzzz.

## A synchronised private message

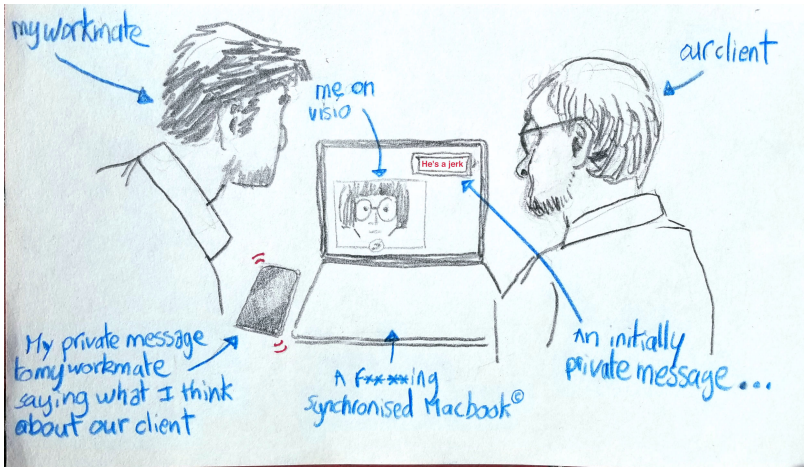

## Books keeping

At the end of the conference, i went to the accountant office to see if everything was set for my paiement as i haven't been asked about invoicing or anything yet. The clerk asked my eid-card and after connecting to some web application, hold a cardboard folder, and retrieve a paper list. After browsing through pages she took a fluomarker and scratched my name on it. Than, she hold me a paper envelop. "*Here you are, she said, your plane ticket are in you electronic wallet, you have to get your covid passenger form and fill it and be sure that your vaccination passport is up to date or have a 48 hours negative test that you can show at the custom and plane company counter*". I nodded, took my envelop. I decided not to argue on the fact that i won't travel by plane but by train, guessing that it's this clerk general polite discourse to the long list of speakers that she must see daily.

I took my rolling suitcase and adjust by backpack than i walk the door of the university premices. Damned, i still hold that envelop. So i stop, put down my backpack than, for some reason decided to have a look into that enveloppe. I was tired, three days of talks and chats and dinners and social physical networking. I'm not a social person. I do not mean that i don't like people, it just, well, i don't use online social networks exactly because of this. I don't want to keep long distance connections, just for the sake of it, just because i can do it. Just to say that if i was in better shape, i would have opened that envelope and asks questions about it right when it was handled to me.



So i opened it.

The square in front of the university was battered by heavy winds. I hold a letter with a plastic card glued to it. It was labeled amazon and had a QR code on it. The letter said : Thank you for contributing to these three days of conferences. \_Infrastructural interactions\_ is rewarding you by offering you the enclosed amazon voucher.

I was surprised and appalled so the envelope slipped from my hand with a gust of wind, and soon was so far that i could not get it back.

Holding firmly my voucher letter i went back to the accountant office.

*"Is there something i can do for you ?". "yes i was there a couple minutes ago and i have a question about my fee...". "oh did i gave you the wrong envelope?" "no, i don't know, my name is" "can you hand me the envelope over ?" "no it has slipped in the wind". "That would be a problem, because i need the envelop references in order to verify..." "The thing is, inside there was an amazon voucher...". The clerk stopped and stared at me. "Yes" "Is that..." "Oh, you are one of those... We do pay researchers with gift vouchers for now a year. I can help you setting up an account if you need. I know a lot of scholars doesn't "But, it's..." "or, if you really reluctant with buying online we do provide, in such a case, rare vouchers to Mark and Spencers retails stores instead, but hence, you'll also need to set up an account to their online store in order for us to transfer the money on M&S vouchers system. What would you prefer?" "Frankly, a wire transfer, a check, cash.", " I cannot do that".*

The clerk was slightly changing her polite gentle tone...into a dryer rigorous condescending one. I tried : *"I can invoice you, i mean, usually..."*.

*"Could you give me you eid again ?".* Time was ticking... i had an hour and half to my train, and the train station was not so close from there.

*"I can see your an affiliate of that university, right, so you are not an independent researcher right? Let me see what i can do. Independent researcher in last resort we sometimes wire them to their paypal account, but i haven't done this for awhile..." "Paypal?" "Yeah, you have a paypal account right ?" "... "Oh, God... Anything we can use? Your google account maybe ?" "... i don't have one of those." "Well, we need to figure out something i can bought for you, i can... i don't know. A netflix or apple voucher?" "No i don't."*

*"Oh god, you don't make my life easy... I guess, you don't want to simply let this go, right? (the voucher was of 400£)... Well, it's really simple to get an account on one of this places you know. Really. I mean, i don't get you guys. There is always one or two people like you per conferences...Do you still live in year 2000 or something ?..."*

At that point, i was about to loose both of my voucher and miss my train than..."*Oh, i know. I give you my email and you know what, if order you books ? Send me a list... This, i can do if you want...You scholars like books right?.*

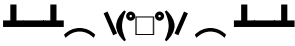

In the work that I do the organisation uses Microsoft Teams and Zoom, no it was Teams I think, whats the difference? In the first meetings we had I didn't want to install the app or program on my laptop, and so in first meetings I joined straight from browser, the Teams, or Zoom, house party, Jitsi or was I on Tiktok? I dunno... In the first meetings I was just staring at the icons, wondering why everyone was refusing the camera. In the first meetings even the head of the organisation didn't have a camera. In the first meetings I was still working but I gradually just relied on no camera too, taking the meetings from bed, from the floor, from wherever i felt the fuck comfortable. It started to really change the work I was doing, and i started to dream of the abolition of work, I mean before when we all had to sit in those team meetings and see each others faces, all encouraging each other too work. I mean I started to build like a beavers den or a like a badgers burrow near where my desk would be, at one point I just took the desk broke it down, and burnt it outside. I mean I started to do my spreadsheets as if I was a beaver and before long I pretty much realised beavers don't care about spreadhseets. It took me some meetings to realize that that was the reason why I couldn't see my colleague's faces, because the software, that I think it was Zoom, or Jitsi, or was it that time i got invited to queer haus on mastadon no sorry it was Team I guess , allows you to see other people's faces only if you install the program. I had only Facetimed with my mom once a week until that day and she could see my burnt desk. You know when your mum answers the videocall and you still cannot see her face because the phone is so close to her face. what if I hadn't seen their straight faces for the last 12 months? - I think I rather not have seen my colleagues faces all semester, sleepy or full on make up on and showing of pajamas and eye bags, but mostly my own nap face was there. During the months of not seeing my colleagues faces, their faces slowly changed. After the installing, trading space on my device for faces, their motion changed. What ever happen to phone calls?! No file to safe after, no records, tracks... Im so paranoid this days, it really freak me out. I never got the invite for fucking Clubhouse. 🙄🙄

# Melting your CPU, one meeting at a time!

+++++

Melting your CPU, one meeting at a time!

A stab in the dark at team building

```

          _...--\
        _...--  \
      _...--    _...--
    _...--      _...--  |
  \ o          _...--____...--""
  \_...--\
  |        \

```

```

+-----+
+-----+
+++++ micro ++ soft ++ protest +++++
+ against the unequal distribution +
+++++ of terms and conditions +++++

```

Join us in the blackout room!

+++++

# Proxy Power

Once upon a time, a device who was relied on heavily began to age. It took them longer to feel a tap, even longer (more forever) to use an app. And even worse, (access to THE SPACE denied)

Other phones that were also aging, had other issues but felt more and more annoyed and frustrated, so they met up one day for a big cup of coffee... With cracked screens and lint-filled ports, they decided together that they needed a new kind of power: PROXY POWER.

Characters:

- The Old device

- The Newer device
- The hero (a caring relative)
- The villain (state employee)
- The user (may or may not have covid)
- The space (the user is trying to access)
- The digital infrastructure

## **Addressable targets**

*"Addressable targets do not always receive what they deserve"*

## **Faceless kids**

I always resisted the Fb account. For various reasons. Among other, political. I'm not social, if social means social networks. Not interested. Not willing to stay in touch for the sake of staying in touch. After over 10 years of existence, FB was still a mystery to me. I found it almost exciting to sneak over people's shoulder, trying to figure out what kind of interaction they would have there.

Then my daughters started to go to school. One day, they came back home with a small piece of paper, asking for parental permission to publish pictures of the class. On the school's FB account. I immediately refused. This answer, as I quickly find out, was actually not an option. It wouldn't be fair to deprive all the other kids from group pictures, they say, just because of your daughters. What we could do, they continue, is to replace their faces with emojis. So they can't be recognized. What difference would it make in the end? Well, ok, I say. As long as they do remain hidden.

The next year, I gave in. Turns out my daughters had been the only kids carrying ridiculously large emoji faces all over the network.

But still. Me, their faces I cannot see.

Because I have no Fb account.

## **Losing the loss**

I suck at finding my way. It has not always been the case. I was pretty good, actually. Maybe one of the best delivery man of the little Pizza Hut restaurant I was working in around 2010, in the city of Lyon France. At this time, all the digital orientation apps that we daily use nowadays wasn't so wide spread. Not every one had a GSM and we were very limited in terms of data. 10 years ago, only ten years. In fact, the main changes took nothing more than about 2 years. When I left it, delivery world wasn't the same than the one I was born in, as a delivery guy.

2011, August. Hell heat. Four guys chilling in front of a Pizza Hut, floating in their corporate grease-stained stinking clothes, smoking cigs, waiting for orders. « It's going to rain, you should go there through the tunnel, then take the little René Leynaud street. Its so narrow that less rain falls in. » At this time, we were constantly talking about the city, sharing tips and secrets. The city... Kind of a profound knowledge that we all try to learn as deep as possible. An obscure book full of freaky things and people. It scared the new ones, naturally. The city seems to had fun losing them in its depth. We were totally respecting the bluster of the most experienced ones. They deserved to be proud. And they were actively helping the beginners. At this time, a course was a little urban adventure that starts with a little palpitation within the heart, animated by a slight fear. That excitement came from the constant risk of loss. We lost ourselves all weeks, all days for the beginner. The way was fundamentally precarious, brittle. The way wasn't precisely known before it was took. At any time, the city could turns against the way, scramble it, take it into its maze.

Our equipment was made of dirty torn giant maps roughly stuffed in our pockets. But the city also gave helps sometimes, with its signs, landmarks. And with the bus stop maps. God bless the bus stop maps in 2011. To be mastered, the way needed all of our strength, and a solid equipment. We were advising each other. Not only about the fastest way but the nicest one, the most beautiful, secure, calm one. We were always searching for this perfect, ideal way. I finally knew the city. Not totally, for sure, it's endless profound. But I knew it well. Better than my delivery boys, I was finally helping by sharing rare urban secrets. Loss was real, recurrent. The risk of loss was a fundamental knowledge that structured the organization. Our managers knew it, assumed it, respected the loss. When we happened to be lost, we called them for help and they were like partners in crime, copiloting us when we need. Loss was real, I said, but slightly emphasized by us, the delivery guys. Sometimes, we were faking loss to pick something up from our homes, to meet a friend, to take our times, to chill in a beautiful place of the city. Everyone knew that. Even the managers. And it was ok.

The change started with a little machine that was promising to help me with loss. It was a car GPS, a Tom-Tom. I bought it so as not to fear about the way, not to fear about loss. I bought it so as not to have to conceive the way before starting it and not to memorize it and be vigilant all along the way. I bought it so as not to fear, not to feel, not to work. And unfortunately, it worked perfectly. No need to speak with each others, to collect some precious fragments of their experiences. No need to fear. No need to think. Nothing to do more than obeying to the fake voice of the machine, Tom-Tom and soon Google. With the necessity to think and feel, I lost the knowledge of the city itself. Gradually, we all lost it. And we lost the right to be lost. With digital orientation apps, loss is not a possibility. Why should it still be tolerated ? « — I was lost ! — Lost ? Hahaha. Stop cheating me. It doesn't exist, it's not possible ! » The work naturally, or technically started to accelerate. We weren't authorized to be lost in space, neither to lose

time. Losing the loss was losing the knowledge of space, the thickness of time, the taste of the way, made of an exciting constant doubt. We lose the loss.



FIG. 1

