

# VICTIMS

*a work by* John Hejduk

TEXT · I  
*Architectural Association*  
*London*  
1986

720.  
28  
HEJ

7765841

720.28 HEJ

**Integrated Learning Resource Centre**  
41-71 Commercial Rd, London E1 1LA  
Tel: 020 7133 2371 (Renewals)  
020 7133 4292 (Enquiries)  
020 7423 0000 (Switchboard)



Catalogue: <http://catalogue.londonmet.ac.uk>

**3 WEEK LOAN**

This item must be returned not later than the last date stamped below. You may renew this item by telephone or online if not reserved by another reader.

--	--

PN 7765841 8



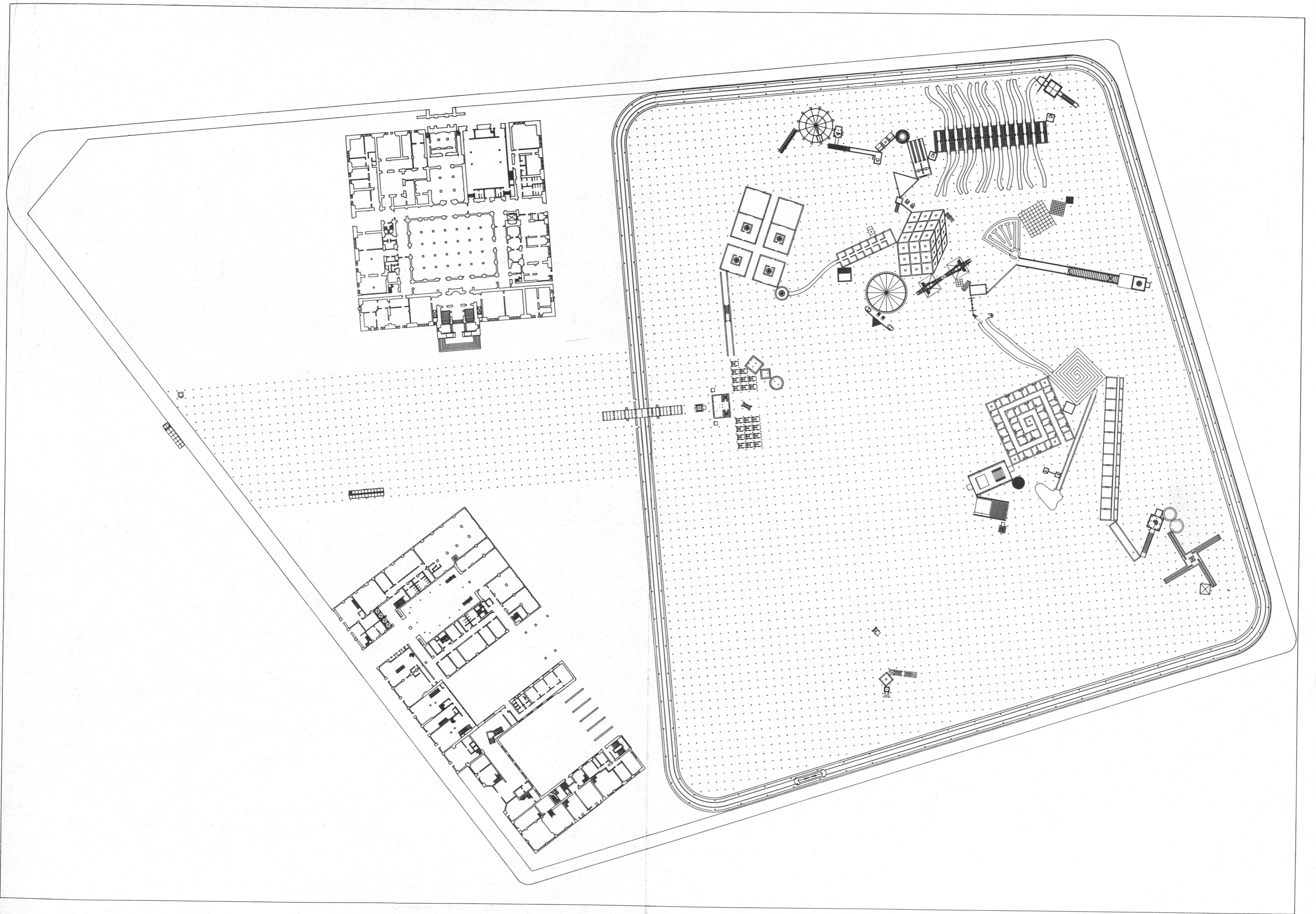

LIBRARY AND INFORMATION SERVICE  
POLYTECHNIC OF NORTH LONDON  
HOLLOWAY ROAD  
LONDON N7 8DB

# VICTIMS

*a work by John Hejduk*

TEXT · I  
*Architectural Association*  
*London*  
1986

New site plan (fold out)  
Site had formerly contained torture chamber during WWII.

POLYTECHNIC OF NORTH LONDON	
0904503771	
720.28 HEJ	
7765841	

*to*

David Dolgenos:

Jay Fellows:

&

David Shapiro

## Introduction

A place to be created over two 30-year periods. A growing, incremental place - incremental time.

The site is enclosed and bordered by two hedges. Running between the hedges is a trolley track for the round-the-clock trolley. The main entry to the site is near the bus stop. At the bus stop is a dual clock. At the top of the clock is a moving set of blades mounted on a shaft activated by a turntable. Suspended from the turntable is a shaft with a pendulum attached. The pendulum is fixed - no movement - fixed time. On the side of the clock tower there is a cantilevered hour-glass. The hour-glass spins perpetually - moving time. The particles of sand are in constant motion. From the bus stop to the entry of the site's drawbridge there is a walking surface covered by trees. The site visitors can go over the drawbridge into the hedge-enclosed site, entering through the gate-house, or the visitors can take the trolley which circulates around the site's periphery.

Within the enclosing hedges the site is marked off in a grid locating the positions of the evergreen saplings. The saplings are all planted at once in the gridded site. The trees reach full maturity during a 30-year cycle.

This catalogue of 67 structures is presented to the City and to the Citizens of Berlin. One possibility is that all 67 structures can be built over two 30-year periods, the other possibility is that none of the structures is built. A third possibility being that some structures are built. The decision lies with the City and Citizens of Berlin.

*Each structure has been named.*

The site plan herein presented is *one* possibility for the total completion. The arrangement of the structures is only a suggestion. The concept of another structural ordering is open. A parameter to be considered is that each named structure can be contacted at three points (points of tangent); a sort of pointal-connective tissue floating within a nature-grid.

The Citizens of Berlin would decide the time sequence for the construction of the elements and their three-point connective relationship.

The project is conceived as a total growing vision. The trees at first are lower than the structures, then throughout the years, in some cases, the trees transcend the heights of the structures.

The problem and decision of removing the trees to make way for the construction-creation of a structure is of particular importance. A dialogue on this matter will by necessity have to take place.

A child of Berlin might be five years of age when construction on the site is commenced and could conceivably be 65 years of age when construction is completed.

\* The concept is that the structures can be in a time sequence similar to the trees and to the Citizens.

The first phase would be to mark the site indicating the location of the enclosing double hedge, the trolley track between the hedges, the telephone poles at the side of the tracks, the position of the bus stop, drawbridge, gate-house, and the pointal markings of the grid locating the future placement of the evergreens.

*Individual*

Proceed as follows:

- 1 Lay trolley track
- 2 Install telephone poles
- 3 Construct drawbridge
- 4 Build gate-house
- 5 Plant evergreen saplings
- 6 Fabricate clock tower
- 7 Determine manufacturers of bus and trolley vehicles
- 8 Select steel fabricating process
- 9 Select granite
- 10 Select wood

## Thoughts of an Architect

- 1 That architectural tracings are apparitions, outlines, figments.  
They are not diagrams but ghosts.
  - 2 Tracings are similar to X-rays, they penetrate internally.
  - 3 Erasures imply former existences.
- 4 Drawings and tracings are like the hands of the blind  
touching the surfaces of the face in order to understand  
a sense of volume, depth and penetration.
  - 5 The lead of an architect's pencil disappears (drawn away)  
metamorphoses.

To take a site: present tracings, outlines, figments, apparitions,  
X-rays of thoughts. Meditations on the sense of erasures.  
To fabricate a construction of time.

To draw out by compacting in. To flood (liquid densification)  
the place-site with missing letters and disappeared signatures.  
To gelatinize forgetfulness.

1 Horticulturist  
2 Gardener  
3 Rosewoman  
4 Metalman  
5 Park Attendant  
6 Inhabitants  
7 Drawbridge Man  
8 Trolley Man  
9 Mechanic  
10 Operator  
11 Children JJ  
12 Children SP  
13 Children SB  
14 Children S  
15 Children MGR  
16 Children SP2  
17 Children SS  
18 Children PT  
19 Physician  
20 Nurse  
21 Optometrist  
22 Painter  
23 Musician  
24 Poet  
25 Soloist  
26 Musicians  
27 Dancer  
28 Librarian  
29 Typesetter  
30 Poem  
31 Mask Repairman  
32 Watch Repairman  
33 Paper Restorer  
34 Carpenter

1 Trees/Shrubs/Flowers  
2 Garden  
3 Rose Arbor  
4 Wall of Metal Flowers  
5 Park/Entry Gate-House  
6 Maze  
7 Drawbridge  
8 Trolley  
9 Box Car Parts  
10 Moving Stairs  
11 Jungle Jim  
12 Sliding Pond  
13 Sand Box  
14 Swings  
15 Merry-Go-Round  
16 Spinner  
17 See-Saw  
18 Picnic Table  
19 Office Tower (Genetic)  
20 Dispensary  
21 Sight  
22 Studio A  
23 Studio B  
24 Studio C  
25 Labyrinth  
26 Music Hall Units  
27 Dance Platform  
28 Book Towers/Fiction/Semi-Fic/Non-Fic  
29 Type House  
30 No More  
31 Mask Shop  
32 Watch Shop  
33 Work Shop  
34 Wood Shop

35 Plumber  
36 Shoe Repairman  
37 Clothman  
38 Crochet Lady  
39 Shade Woman  
40 Security  
41 Researcher  
42 Identity Card Man  
43 Stampman  
44 Accountant  
45 Keeper of the Records  
46 Giver of the Keys  
47 Taker of the Keys  
48 Iceman  
49 Fireman  
50 Zoologist  
51 Butterfly Collector  
52 Catfish  
53 Peacock  
54 People  
55 Child  
56 Judge  
57 Room for Thought  
58 Room of the Innocent  
59 Room for Those Who Looked  
the Other Way  
60 Passengers  
61 Toll Taker - Toll Taker II  
62 Time Keeper  
63 The Dead  
64 The Travellers  
65 The Exiles  
66 The Disappeared  
67 The Application

35 Water House  
36 Shoe Shop  
37 Shop of Clothes  
38 Crochet Chair  
39 Shades of Text  
40 Structure  
41 Office 1  
42 Identity Card Unit  
43 Stamp Place  
44 Office 2  
45 Record Hall  
46 Key Place  
47 Key Storage  
48 Ice House  
49 Fire Place  
50 Copies of Recaptured Creatures  
51 Collector's Place  
52 Catfish Pond - Enclosed  
53 Peacock's Walk  
54 Park  
55 Playhouse  
56 Stairs  
57 Room A  
58 Room B  
59 Room C  
60 Silo Passage  
61 A Bridge Removed - The Tractor  
62 Ferris Wheel Clock  
63 The Dead Cry  
64 Bus  
65 Attached Units  
66  
67 Passport Building



1 *Horticulturist*

The Horticulturist maintains the trees, shrubs, and flowers in the park. He was originally trained as a stone cutter. The cutting of a dark granite was his main work. He decided to become a horticulturist when a dispute arose as to whether there was such a thing as black granite. He was convinced he had seen it in his travels in Egypt. A gentle man from Hanover explained the differences. He said it had to do with something about the rock being above ground or under ground. The Horticulturist insists that the trees, shrubs and flowers be planted in triangular stone bases (no matter the size or interpretation). Within him there is a sense of unease. He is not sure any more that such words as flower, shrub, tree and park have meaning. To pass time he rides the trolley car. He cannot quite shake the dread of the problem. The first disturbance occurred when he visited the Archaeological Museum in Athens. The removal of the eyes in the bronze sculptures seemed unwarranted. He thought he might have seen a humming bird flying within the concavity of the head. The sound of rapidly moving feathers filtered through the metal.

2 *Gardener*

n. One who tends gardens.

**Garden** (gar'den) n. A place for the cultivation of flowers, fruit or vegetables; ornamental grounds for public use.

The Gardener assists the Horticulturist. Before winter sets in he wraps the shrubs in burlap.

Silk of Sprigs

*no ground flowers are crushed  
by gentle Botticelli women  
an arrow head of flame  
is pulled by the blind-folded  
child angel and projected  
at finger entwined graces  
they dance the sleepwalkers' circle  
apples are glazed with honey  
iridescent aquas filter through  
ancient umber banks  
thorned stems are held in  
willing mouth of Siena  
the wind rising cut from stone  
as wings made of pewter  
shards immeshed  
in arched trunks  
he is a color of scent  
pearl bluegrey entombment  
she flees in transfixed haste  
all swirls lead to a mound  
a hand plunges into petals  
the flushness of a face  
above the oval northern wreath  
a benediction is anticipated  
Mercury carries a Saracen sword  
suspended from the shoulder  
his wand announcing  
the coming of future fertilities*

3 *Rosewoman*

In her youth she cultivated white roses along the southern wall of Perugia. Her life was changed when she visited her Uncle in Benevento. One afternoon as they were descending a slope through the olive trees a large snake (approximately 6 feet)

crossed their path. In her fear she whispered to her Uncle:

"Did you see that snake?"

"See what?"

"That large snake that just disappeared in front of us."

"No."

"No what?"

"No I did not see the snake."

"But how could you not see him, his tail touched the point of your boot!"

"I did not see the snake because I do not believe in them."

She will attend to the Berlin Rose Arbor. The Carpenter has selected the wood for the arbor's structure. The rose to be cultivated will be the black rose. The flower petals will be placed in pewter bowls along the garden path. She anticipates wrapping the rose stems continuously around her naked body until only her eyes are exposed. They are the colour of apricot.

4 *Metalman*

As each rose blooms in the Rose Arbor the Metalman draws it from many points of view. When the rose finishes its growing cycle the Metalman begins the task of capturing the rose in metal. This is accomplished by heating, hammering, and cutting. After the metal rose moves to its perfection he attaches the rose to the steel wall in the park. He is a master craftsman of steel and of metals. He is also making a dress for the Rosewoman, a dress made of metal roses. He is duplicating the rose stems. He thinks of the scent of roses intertwined with the smell of cooling steel and the aroma of the Rosewoman's body.

5 *Park Attendant*

Custodian of the park. He lives in the gate-house (entry to park). The gate-house is situated between two clock towers. One tower has the numbers 0 - 13 running from the top of the tower to the bottom of the tower. The other tower has the numbers 0 - 13 running from the bottom to the top. A blank square rides over the surface of each tower covering the present time. The two blank squares come to parallel alignment.

6 *Inhabitants*

**Maze** (maz) n. 1. An intricate network of paths of passages; a labyrinth. 2. A state of bewilderment; uncertainty or perplexity; to daze or stupefy; bewilder.

7 *Drawbridge Man*

After seeing Carpaccio's *Venetian Bridge* he was inspired to reproduce the bridge shown in the painting (with modifications) for his drawbridge. He and the Carpenter made measured drawings for the construction of the drawbridge. He left unanswered the question of the sense of it all.

8 *Trolley Man*

The Trolley Man was born in Finland. Shortly after his birth his Mother was taken to a northern sanatorium. He remembers that when he was about seven years old he was taken by train to visit her. His Mother's tears froze as solid droplets upon her face. He began to count them, then suddenly stopped, for he sensed they would add up to the days of his life. Before he left the room he asked his Mother if he could have one of the tears. She removed one from her cheek and placed it in his handkerchief. After his Aunt returned him to his home he carefully opened the folded cloth and all that remained was a moist spot.

9 *Mechanic*

In the late 1940s he served as the film projectionist at a military base located in Osaka. His position was to project the negatives of the collected film on Hiroshima after it was exposed. This experience produced in him a horror of projected images. He felt the necessity of working directly with his hands on materials. His work is to dismantle a box car and install the parts (every part) onto a wall in the Berlin park.

10 *Operator*

Near the gate-house stand three mobile structures (electrically powered); a circular stair on wheels, a U-stair on wheels, and a straight-run stair on wheels. These are provided for those who wish to move about the park in a mobile unit. The Operator charges the body.

11 *Children JJ (jungle jim)*

Round steel bars producing a three-dimensional grid, bent nail-pinned joint. The hierarchy of the crow's-nest, a geometric confrontation of biological parts. The armpits of the legs encompassing a tubular section. Upside down the blood rushes to the head.

12 *Children SP (sliding pond)*

The illusions of smooth surfaces. Friction producing heat, clamped legs around buttocks - the slide down.

13 *Children SB (sand box)*

Surrounded by 1" x 1" steel bars 6" on centre, 4' high. The sand was never deeper than 4" and the concrete base made it hard to sit in. Small things were always lost in the sand box and never found. It smelled of urine.

14 *Children S (swings)*

The swings' chains being double-helixed about themselves then suddenly released unravelling into a disorientation.

15 *Children MGR (merry-go-round)*

The view of the merry-go-round would never be the same again when it was discovered that over the winter a nest of coral snakes inhabited the inside of one of the merry-go-round horses. At that moment the shaft running through the back and body of the horse was seen in another light.

16 *Children SP2 (spinner)*

The cars are attached at the ends of a long metal arm. Two cars to an arm. The arm is attached to a central pivot point which connects to the supporting structure. The arm slowly begins to move about a 360° circle, picking up speed until it reaches its maximum. The cars themselves spin in a 360° cycle perpendicular to the other circle.

17 *Children SS (see-saw)*

The 2" x 12" wood plank was too heavy. The inner thighs were bruised because of the right-angled edges of the plank. The weight distribution being unequal. The cruelty of the other one when she slowly moved off the see-saw while you remained suspended.

18 *Children PT (picnic table)*

Picnic table made up of two 'A' frames and six planks nailed with steel spikes.

19 *Physician*

Although a man of science, he has an obsession with mirrors. It is their opacity which interests him. He observes each day meticulously the process of his own aging. (He sees it before his eyes.) He is 60 years old and his body verifies this fact. A surgeon of 30 years, he is constantly feeling the weight of organs. His favourite paintings throughout history are the ones dealing with autopsy. He knows that the heart has weight yet he cannot feel its weight in his own body. He is aware of its presence, though not all of the time. Such things as his own spleen he felt not at all. When his patients visit him for pre-surgical consultation he appears tall, thin and bent over. They do not see his arms under the white coat sleeves. When they are on the operating table they see him in a different aspect. There they see him in short sleeves, his exposed arms thick and muscular. He speaks, "Let us get on with it."

He has concluded that his mind has not aged at all and that there is the possibility of the soul transcending the body. His decision to work in Berlin was made because of the physical erasures and because of the aftertone.

- 20 *Nurse*  
 (nurs) n. 1. A person who cares for the sick or injured, especially one who is trained to do such work. 5. One who or that which fosters, nourishes, protects. 6. entomol. A sexually incomplete bee, ant, etc. whose function in the colony is to care for the young. 8. To take steps to cure.  
 The Nurse assists the Physician.

Bus Ride Through

*Don't walk red  
 lit the snow  
 of an empty school  
 yard wire fenced  
 motorcycle left tracks  
 rippled upon white  
 hands black leathery  
 covered the bars  
 beam illuminated  
 granite window arches  
 moisture silted the  
 crevice smoke and fog  
 womb infiltrated  
 Mount Morris park  
 brownstone entries  
 sheet aluminum nailed  
 tractor man treads  
 roll a brick  
 his gray interior shielded  
 by green eye awnings  
 copper skinned from  
 steel bones  
 Harlem hearses  
 always parked  
 middle of the block  
 its people's cerebellums  
 covered by  
 uneradicated ash  
 all dates implode  
 the garbage cans  
 internally scorched by  
 pine stick fires  
 it is the absence  
 of a wall  
 that penetrates  
 figures perpetually whispered  
 to be silent  
 God damned intravenous  
 social encyclicals  
 blue-frocked sisters  
 of mercy blow  
 an oval breath  
 plaster peels  
 urine analyzed  
 stopped up kidneys  
 fill the lungs  
 Hospital of joint disease  
 moan a loss*

- 21 *Optometrist*  
 The Optometrist has a recurrent dream. He is at one end of the long corridor-room looking in perspective at the wall of the other end of the corridor room. On the wall is placed a typical eye chart, - (two-dimensional). At time-fixed intervals he imagines the chart moving forward towards him. At various intervals it still-stops. Also at each interval the letters on the chart become more and more

three-dimensional until the point where they entirely engulf the Optometrist. At that moment he awakes and is relieved when he remembers the shooting gallery he had seen in Stockholm where at the end of a long corridor was placed a two-dimensional target figure. It progressively moved forward towards the firing mechanism of the gun. At intervals it became more and more three-dimensional until the point where the one holding the gun was not sure if the target was no longer a fabrication.

- 22 *Painter*  
 The Painter is given Studio A in the park in order to paint.

Nature Morte

*He thought he heard  
 it enter the still life  
 although the shutters  
 were closed  
 He sat in the wood chair  
 and waited  
 for the return  
 He dreamed of the  
 cliffs of Le Havre  
 The rooms somehow  
 were always permeated  
 in greens and browns  
 Suddenly  
 a lone gull  
 silently flying appeared  
 wings interweaving  
 within the vertical stripes  
 of the wall paper  
 His soul was released  
 inside  
 it became white*

- 23 *Musician*  
 The Musician is given Studio B in the park in order to compose.

Dutch Interior

*The mandolin intestines of  
 hollowed black crystals  
 slide against the internal  
 curvature  
 ultimately released through  
 the hole of stretched fibers  
 held  
 then diminished  
 in a tap*

- 24 *Poet*  
 The Poet is given Studio C in the park in order to write.

Lampasas Square

*stillness of heat  
 blue that does not move  
 clouds that do not echo  
 darkness that holds  
 endless twirl of fan*

25 *Soloist*

At the heart of the matter.

A labyrinth

A corridor off which are small rooms: each room is separated by a door with a window in it. Each room has hung, suspended on the wall, a chair. A funnel-shaped speaker extends through the roof of each room (for the transmission of sound to the outside).

The Musicians of Berlin pledge that all through the day and night there will be someone playing music, in at least one of the rooms. In fact, there is the possibility of all of the rooms being occupied by a Musician playing his or her instrument. The pieces played will always be different. One can imagine the park being filled (through the loudspeakers) with a cacophony of different compositions.

The visitors who move through the labyrinthian corridor are able to peer into the music rooms. They can see the Musicians playing but they cannot hear the music while inside the structure.

The Musician receives a key from the Giver of the Keys, goes into the corridor, inserts the key into the door of one of the locked rooms, opens the door, closes it, locks it from the inside, takes down the suspended chair from its wall, sits, tunes his instrument, and begins to play. The room is filled with sound which escapes through the funnel loudspeaker into the park. The end room of the corridor is reserved for a composer who uses a synthesizer.

26 *Musicians*

Throughout the park are scattered little separate units. They actually are the parts of a full orchestra. Once during the week the Musicians assemble and take their positions in the separated units and play a score (the same piece). They begin the work at an appointed time, play it through, put away their instruments and leave the park until the next performance.

27 *Dancer*

The Dance platform is for anyone's use. The dance must be performed in silence. One phrase can be whispered.

A Miniature Volume

*how much does  
your heart weigh  
I don't know  
perhaps as much as  
a miniature volume  
I would have to turn  
it inside out  
like a leather glove  
my grandfather gave  
me a sea conch  
to hold I dropped it  
stuck like a top  
under the drift log  
an armadillo shed tears  
he held the fishing knife  
and split the violin  
down the middle  
put his hand inside  
and removed the air  
the limp gut strings  
entangled jelly fish  
nets slipped and  
smothered the swells  
a dead sailor  
filled with water  
like a glass vessel  
a widow walked  
exhaling iris aromas*

*she reached out  
and hugged the fog  
to her breasts  
light beam caressed  
moist surfaces  
night lips blow  
sound Nantucket horns*

28 *Librarian*

She has made the following observations:

*There are three kinds of detectives*

1 *The Fiction Detective*

2 *The Non-fiction Detective*

3 *The Semi-fiction Detective*

1 The Fictional Detective departs from his office in search of the fictional murderer.

2 The Non-fictional (Real?) Detective departs from his office in search of the non-fictional (real?) murderer.

3 The Semi-fictional Detective (Newspaper Reporter) departs from his office in search of the semi-fictional (newspaper report) murderer.

*ALL are Detectives and Murderers.*

29 *Typesetter*

Sets type for Researcher (Office 1), Identity Card Man (Identity Card Unit), Stampman (Stamp Place), Accountant (Office 2), Keeper of the Records (Record Hall), Zoologist (Copies of Recaptured Animals), Librarian (Book Towers).

He uses mechanical and electrical devices.

30 *Poem*

A cube, half made of granite, half made of steel. The upper half is steel, the lower half granite. The cube is split along the diagonal in a series of stepped cuts. The upper part of the cube is able to slide off of the lower section. On each of the stepped faces is an incised poem - the same poem. One is cut into the granite the other cut into steel.

*The unacceptability of the  
erasures  
and of the unaccountable  
disappearances  
wherever and whenever  
throughout the world.*

The cube is opened in the day and closed at night.

31 *Mask Repairman*

The only known shop for the repairing of masks. The Mask Repairman knows the secrets of the masks. The common types of masks are:

1 *The Eye Mask*

2 *The Eye and Nose Mask*

3 *The Full Face Mask*

He collects and saves discarded masks. His prime interest is in the space created between the outside surface of the face and the inside surface of the mask.

32 *Watch Repairman*

His prime objective is to repair time.

- 33 *Paper Restorer*  
The art of paper restoration is practised by the Paper Restorer within the confines of the park. Although a difficult task, she lovingly tries to heal the damaged paper. Her solution is to give the time necessary for a proper restoration.  
Her approach follows:  
"She looks at the paper, at the image and damage. She studies it for a long time. She makes tests to determine the exact chemical nature of the paper, the image, the damage. The damage also exists in her mind, as havoc: when she thinks of the piece of art, she feels the chaos and carelessness of damage. She wants to see only the art, not the damage. . . She is ready to begin. She mends tears. She flattens creases. She cleans the surface. She removes tape. She removes all traces of foxing, of mildew and mould. She lightens the tone, reviving the original color. The damage is healed. The mind of the paper restorer is released from the damage. The art is once again free and inviolate, and the imagination of the paper restorer exults with the clear image of art. Because the paper restorer is happy in the park, the work she does there is performed with an ease and serenity that feels like grace."  
(From a Statement by Janet Lee)
- 34 *Carpenter*  
His position is to do construction for the Rosewoman, to keep the drawbridge in repair and to make a new picnic table every year. He studies the 'A' frame tables in fifteenth- and sixteenth-century paintings. He belongs to the Order of the Carpenters.
- 35 *Plumber*  
(plum'er) n. One whose occupation is the installing or repairing of plumbing.  
**Plumbing** (plum'ing) n. 1. The art or trade of putting into buildings the tanks, pipes, etc. for water, gas, sewage, etc. 2. The pipe system of a building. 3. The act of sounding for depth, etc., with a plumb line.
- 36 *Shoe Repairman*  
He repairs children's shoes.
- 37 *Clothman*  
Various thicknesses and qualities of cloth are stored at the Building of Cloth. The cloth is used for the protection of certain areas designated in the park. The Clothman is in charge of the distribution of the stored cloth.
- 38 *Crochet Lady*  
She arrives at dawn and departs at sunset. She climbs the stairs to her enclosed suspended chair and crochets throughout the day. She usually finishes a piece before the snow falls. Each year she selects a tree which she covers with her shroud of crochet. She carefully drapes the branches of the tree and leaves her work to the elements. Her sadness makes the peacocks screech.
- 39 *Shade Woman*  
Shade  
Shadow
- 40 *Security*  
A motorised vehicle (electric) which can move throughout the site. It is up to the City of Berlin to decide if security is put into motion or whether it remains fixed-still, or possibly if it is there at all.
- 41 *Researcher*  
When did it begin  
A point of no return  
Speech to a whisper  
Then to a silence  
No end to it

- 42 *Identity Card Man*  
Collects identity card  
photographs card  
Projects film of card onto screen  
Once -  
destroys negatives  
explicit faith in memories  
hallucination  
of signatures
- 43 *Stampman*  
Removes the stamps from the envelopes of unanswered letters. Acts as a depository of envelopes, dating from approximately 1931 to 1946. After careful removal of stamps he gently places them in between the pages of leather covered notebooks. When the notebooks are filled he places them in metal boxes which then are stored in the Record Hall. In order to remove the stamps he puts the envelopes in a bowl of water and waits patiently for the stamp to float to the surface. Under certain conditions of light his face can be seen as a history of stamps. When he cries his tears are made of ink. The wax sealed envelopes impress him as representing a more civilized time. In breaking the seal one felt that a three-dimensionality was being opened.
- 44 *Accountant*  
Keeps precise records of accounts. Is determined to keep the memory alive. Does not believe in the abstraction of numbers. For each number there is a name and a thought.
- 45 *Keeper of the Records*  
**Centipede** (sen'te'ped) n. An elongate, chiefly nocturnal myriapod (class Chilopoda) having a pair of legs to each segment. The front pair being modified into poison fangs. (LF L. Centipeda Centum hundred + Pes, Pedis Foot)
- 46 *Giver of the Keys*
- 47 *Taker of the Keys*  
The Giver of the Keys gives the keys to the music rooms. The Taker of the Keys takes back the keys from the music rooms.  
They have a strong connection to the Researcher, the Identity Card Man, the Stampman and the Accountant.
- 48 *Iceman*  
The Iceman came from America to Germany. It thrilled him to pick up a block of ice with his ice-pincers. He mulled over anatomical drawings depicting the measurement of skulls. He thought the instruments looked alike.
- 49 *Fireman*  
He keeps the fire-place operating so the Metalman can create the roses.
- 50 *Zoologist*  
He was shown documents, writings, drawings, paintings of mythical animals and simply could not be convinced of their existence. Late one evening he visited the Archaeological Museum in Athens. On his way there he rested on a bench under an orange tree. He was thirsty and reached up to take an orange off the tree. The orange he found in his hand had the weight of a steel ball. It was very hot and burned the palm of his hand. He let it slip from his hand, it fell to the ground with a thud. He brought the heel of his shoe down on the fallen fruit and smashed it into vermilion-white crystals. He looked up to a window of the museum and he saw the head of a bull staring out at him. He never entered the museum for at that moment he knew that there were no myths.

- 51 *Butterfly Collector*  
Collects butterflies  
The irreconcilability of  
catching butterflies and  
of writing fiction.
- 52 *Catfish*  
(kat'fish') n. Pl. - Fish or fishes  
Any of numerous silurid fishes having sensitive barbels around the mouth.
- Barbel** (bar'bel) n. 1. One of the soft threadlike appendages to the jaws, chin, or nostrils of certain fishes functioning as the organ of touch.
- 53 *Peacock*  
(Pe'kok') n. The male of a gallinaceous crested bird (Genus Pavo) having erectile, brilliantly iridescent tail coverts enormously elongated and marked with ocelli or eye-like spots on the neck and breast of a greenish blue. Male peacock body to 36" long; tail coverts to 6 feet.
- (Pe'kok') A star of 2.12 magnitude in the constellation Pavo.
- 54 *People*  
The trolley is for the people to board and ride. The trolley circles the park-site. It stops at the intersection of the drawbridge. It is electrified by overhead lines till the point of the drawbridge, then they drop beneath the ground. The passengers must push the trolley under the drawbridge to the position of renewed electrification. When the trolley approaches the drawbridge a stop gate prevents the inhabitants entry or exit. The drawbridge is raised so the trolley can be pushed through underneath.

Berlin Looms

*the vanished can  
still be felt  
banal stanchions  
of rusting concrete  
envelop the outline  
stretched wire produces  
the void  
air can be blue  
the smoke geometric  
ice cream licked  
from the rafters  
the obelisk was moved  
on axis  
the dry bark of  
linden trees split  
across the street  
the moist shadow  
of barges rippled  
october ash felled  
the pharmacist's cough  
drops bought  
for a mark  
the black eagles swept  
the boulevard clean  
the canal became  
a gelatin  
the plan had been  
erased*

- 55 *Child*  
The wonder of receiving a clear empty jelly jar at the age of six. Of being given a paint brush and two jars of enamel paint. One filled with blue paint and one filled with yellow. Of being asked to paint the outside of the clear jelly jar with the blue paint and letting the paint dry. Then of being asked to take the yellow paint and with the tip of the brush running it around the outside rim of the jar and watching the yellow paint drip down in streaks over the recently painted blue. The house of the Child is both, 3/4 size.
- 56 *Judge*  
Definition: Noun or verb?
- 57 *Room for Thought*  
(THOt) n. 1. The act or process of using the mind actively and deliberately; meditation; cognition. 2. The product of thinking; an idea, concept, judgement, etc. 3. Intellectual activity of a specific kind: Greek Thought. 4. Consideration; attention: Give the matter some thought. 5. Intention or idea of doing something; plan: All thought of returning was abandoned.
- 58 *Room of the Innocent*  
Innocents' Day December 28 marking of the day of the slaughter of children by Herod.
- 59 *Room for Those Who Looked the Other Way*  
(ROOM, ROOM) n. 1. An extent of space used for some implied or specific purpose.
- Roomer** n. A lodger
- 60 *Passengers*
- 61 *Toll Taker*  
He moves the park bridge each day to another place. He carries in his coat pocket an old newspaper printed in Chicago recording the following events:

Chicago - The Recapture 1908

- 1 *The prefabrication of Mythical Animals*  
*The precise construction of Puppets, Marionettes and Mannequins.*  
*The building of a Hall, Merry-Go-Round, Shooting Gallery and Operating Theater.*  
*The production of a Fireworks display.*
  - a. Minotaur
  - b. Griffin
  - c. Gorgon
  - d. Unicorn
  - e. Chimera
  - f. Satyr
  - g. Dragon
  - h. Pegasus
  - i. Basilisk
- 2 *Workshop for the fabrication of Puppets, Marionettes and Mannequins (School for construction)*
- 3 *Mythical Beasts*
- 4 *Children manufacture Puppets, Marionettes*  
*The Teachers: Italian & Japanese*
- 5 *New plays for theaters written by area residents*
- 6 *Study of the mechanism for the suspension of bodies: Active/Inert*
- 7 *The nesting of snakes within Merry-Go-Round horses*
- 8 *The blurring of edges: Japanese Marionette Theater*  
*Italian Woman Cellist*
- 9 *Flaubert's crucifixion of roaring lions*

- 10 *Building of a Ferris Wheel (2-dual) (dual time)*  
*Ferris Wheel 1 Single car containing a man*  
*Ferris Wheel 2 Single car containing a beast*

*The circumference of the Ferris Wheel car almost touches tangentially for a moment the circumference of its opposite - (man/beast eyes are on direct horizontal line for that moment).*

*One wheel moves clockwise, the other counter-clockwise.*

- 11 *A Clock Tower where a blank surface moves over the numbers covering present time.*
- 11A *Gate-house - Security - Vehicle of Balloon Woman - Lake Barge*
- 12 *Six month construction of Chicago Hall. When complete all Puppets, Marionettes and Mannequins are suspended from Hall's rafters (mechanism is suspended)*  
*Hall filled with created objects/suspended silences*  
*Can be raised or lowered*
- 13 *Main Hall has connected unit which contains exposition on the History of Mythical Animals (from each Country). This unit is also a factory where animals are reproduced. After completion of fabrication/reproduction all Animals are impaled on a vertical Merry-Go-Round shaft. They are then installed, and begin their circular journey. The Merry-Go-Round is enclosed within a high circular wall. At the top of the wall a cantilever stadium is erected. The movement of the Myths can be observed from above: their cycle is slow.*
- 13A *Series of cages for the internment of recaptured Mythical Animals. Also for the exhibition of familiar beasts.*
- 14 *At the opposite end of the Hall there is located an Operating Theater. From the south wall of the Hall a long extension is added; a Shooting Gallery is constructed. The long Gallery has side extensions. The farthest away from the point of firing-exit is a two-dimensional flat mannequin. From a distance it appears to be abstract. Approaching the firing-mechanism a progressive series of mannequins move into more and more three-dimensionality until the completed figure faces the barrel of the gun, point-blank. After the explosion this body is removed to the Operating Theater for an autopsy which is monitored throughout the Fair.*
- 15 *The Fair ends in a display. All Mythical Animals, all Puppets, all Marionettes and all Mannequins are impaled on vertical rods that have been placed in the Lake water. A Time Keeper equipped with a flame-thrower sets them on fire. When ash on water disappears the Audience retires into their own.*

- 62 *Time Keeper*  
 He controls and operates the dual Ferris Wheels. The Ferris Wheels are enlarged clocks. One Ferris Wheel having cars moving clockwise, the other Ferris Wheel having cars moving counter-clockwise. The numbers/hours of time are painted on each Ferris Wheel car, there being 12 numbers, 1-12. The single hand of the clock is fixed and the numbers move about the hand. On each Ferris Wheel there is an unnumbered car which can be considered the 13th number or 0. In the clockwise moving car a man is placed, in the counter-clockwise moving car is placed a beast. At the moment of horizontal tangentiality the eyes of the man and the eyes of the beast are in direct horizontal alignment. At that moment the Time Keeper stops the Ferris Wheels to note the recognition and to recapture past acts. The Time Keeper then accelerates the Ferris Wheel to make up for lost time, upon re-movement the beast roars and the man remains silent.

- 63 *The Dead*

- 64 *The Travellers*

They are brought to the park by bus and must cross over the drawbridge to enter. A trolley runs peripherally around the whole site but there is no way to enter the park from the trolley. The trolley is enclosed between two 14-foot high hedges which surround the inner site. Telephone wires suspended on wood piles follow the course of the trolley. The lines serve the park alone. There are no calls beyond the edges.

- 65 *The Exiles*

To be an exile in one's own skin.

- 66 *The Disappeared*

Irreconcilable numbers.

- 67 *The Application*

Passport Building.

JUNE	I	<p><b>Book Towers:</b> Elevator cab open. Elevator cab has a lamplight suspended from the bottom of the cab and a lamplight projected on top of the cab. The Book Tower's interior peripheral walls are lined with oak bookshelves containing books. Since the tower is unlit a miner's headgear is provided for the passenger so the books can be searched out. Looking down the book shaft (as he rides up) the passenger sees a faint light illuminating the edge stacks. There are two levels at the top of the tower:</p> <ol style="list-style-type: none"> <li>1 <i>Elevator exit platform, machinery platform.</i></li> <li>2 <i>Observatory platform.</i></li> </ol> <p>The three external stairs (one stair for each tower) are suspended from the exterior of the tower. They have two possibilities:</p> <ol style="list-style-type: none"> <li>A. <i>Stair ending at a telescope.</i></li> <li>B. <i>Stair ending at open-ended platform (with no protective railing).</i></li> </ol> <p><b>Book Tower Structure:</b> Reinforced concrete, steel clad  <b>Cantilevered Stair:</b> <i>Lizard on a vertical wall</i>  <i>Biological fragility of pure geometry.</i></p>
	2	<i>One hundred thousand incinerated in six seconds - Japan</i>
	3	<p>The Death Penalty being reinstated in Salt Lake City by firing squad (Reported Marksmen selected by volunteering)  Firing squad of 6 or perhaps 8  <i>2 blanks are issued</i></p>
	4	<p>A Governor of State signs into law  Execution by injection  Possibility of the claim of a more humane execution  <i>Is it a physician who injects or a para-medic?</i></p>
	5	<p>The injection of a plant substance between the discs to dissolve gelatinous material: the particles fall into the internal cavities of the body. An injection at the base of the skull: the particles of the brain rising along the surface of the internal cavity of the cranium.</p>
	6	J. calls by mistake looking for a book he loaned that never was returned. We speak of tracings, erasures, overlays, and X-rays.
	7	<i>G. claims that she was born in Germany.</i>
	8	<b>The pointal system of electronics.</b>
	9	H. speaks of a gentle wind pushing him at his back all during his youth. Now in old age the wind is in front of him creating a fierce suction which steps up his acceleration...
	10	<i>Thoughts relating to Victims.</i>
	11	<b>Memory has a time limit for all.</b>
	12	Sailboats gliding on a lake while canal barges dump their refuse.



- 13 *Berlin Steel: Exposed*  
*New York Steel: Hidden*  
*Chicago Steel: Hidden (its after-image exposed)*
- 14 **Maze-labyrinth:**  
**The corner rooms have no possibility of entry.**
- 15 The boat whistle calling while Angela is lost in the stone corridors. She can be heard crying, but she cannot be seen. This story was told by M. It begins to rain and she follows the rivulets to the sea tapping the vertical walls with a wood mallet sounding the earth for echoes.
- 16 *The chairs in the corner rooms are made of steel and are bolted to the concrete floor.*
- 17 **There are 48 rooms and a synthesizer.**
- 18 The modern minotaur would use the thread to disguise the horns.
- 19 The nesting place of gulls smells of their defecations and of cracked clam shells dropped from a height onto stones.
- 20 **The decision to put wires underground, the voices transmitted through earth instead of air. A matter of densification.**
- 21 *Piglet-eardrums being eaten at a northern architect's transplant. They were served up as being snails.*
- 22 The police car was parked on the sidewalk sitting under chestnut trees as the van approached. It moves off the curb as a crocodile moves off a sand bank. (The image from a movie about a kidnapping.)
- 23 *The relationship of official terror and the cut of a uniform.*
- 24 6 x 9 ROOM  
 9 x 9 ROOM  
 The decision not to draw people in it.
- 25 **Hook:** A piece of metal or other material bent back or having a sharp angle for catching hold or hanging things upon. Bent piece of metal barbed.  
**Chair:** Separate seat for one.
- 26 *Premonition:*  
 As if the heart was encased in blackboard slate and a piece of chalk was scratched along its surface. The disintegrating white flakes mixed with the blood.
- 27 It was 1936, his Father descended from the West Farms trolley, he approached the catholic protectory wall and told the officer that he was his son. The officer asked the boy if he was his father, the son said "No".
- 28 **Is it possible to take 66 separate drawings and make a negative of each, take all 66 negatives putting them one on top of the other and to print them simultaneously? Will it all blur?**
- 29 **Blur:**  
 Dimness, confused, disfigure.

30 Eagles emerge from the eye sockets of Poseidon as the encrustations of sea anemones are scraped off his metal skin.

- JULY** 1 *She is the cellist and promises to be there on time.*
- 2 **Hawthorne's obsession with northern drownings.**
- 3 Looking at the facts in disbelief.  
 A German Mathematician has the proof.
- 4 *She puts her ear down to the cello as if she is looking to hear heart beats. Her ear is warned.*
- 5 **The support system for the alphabet... monstrous.**
- 6 Her hair (becomes electrified) as she begins to move the bow across the string. Her unearthings have to do with the findings of the notes.
- 7 **The former canal boat captain flips the switch and adjusts the dial.**
- 8 Flying from Frankfurt to Berlin in the early morning; the rivers of Germany are mercury placed on the surface of milk glass recently heated, moulded, and left to cool.
- 9 *They know why architecture is a monochromatic pursuit.*
- 10 The pond in back of the farm house was remote. At its south end it was enclosed by a dam-like wall. At its north end was a shallow swamp spotted with grey trunks of dead trees. The farmer's son said the pond was filled with snakes, this was true. The sound of the row boat oars gliding through the weeds heightened the general silence of the backwater. Through the thick underwater growth a line was dropped. Moments later the first catfish was caught, the experience was unsettling. It appeared that the weight of the catfish was concentrated in the head, the barbels remnants of after birth. It was the first time that he set eyes upon a fish head that had the volume and shape of a human head. He extracted the hook and demanded to be taken back to the shore.
- 11 *The Uncle of the Farmer spent his idle time walking along the edge of the pond blowing the heads off the snakes with a 22, sometimes he shot turtles.*
- 12 The excitement of the farm house inhabitants when the chicken hawks circled the barns, R. firing indiscriminately into the air. His mother shouting that he was wasting his time as she sat on the wooden stool plucking a chicken.
- 13 *The day the pig was butchered was the day he decided it was time to leave and go home.*
- 14 "Your insistence on the recapture of mythical animals perplexes me. What is behind it?"  
*"The very thing that draws me to Berlin."*  
 "Ariadne eventually did disappear."  
 "In the myth or the reality?"  
 "It makes no difference."
- 15 **Newspaper Morticians working on the alphabet.**

- 16 N. excitedly greeted his guest anxious to read to him from the new work in progress and show him the catalogued butterflies.
- 17 **The consequence of the death, elimination and the disappearance of a single letter.**
- 18 Johannes in translating from German informed me that one of the requirements was that a children's playground should be included. He also states that he believes the ruins of the torture chambers are still on the site. Coincidental that I had included children's playground equipment *before* I found out about programme requirements. I think my thoughts are of another kind regarding these items. Above use of the word programme doesn't fit.
- 19 *Atomic Light: Hiroshima bleaches the very shadows the evaporation of white protons, electrons and neutrons in disarray as when the hive has lost its Queen the bees flying in cacophonous panic their terror of abandonment.*
- 20 **Being drawn in.**
- 21 Transferences.
- 22 *The word "vase", always a dark word.*
- 23 The logic of the digital clock?  
A clock where the numbers move.
- 24 *The invention of the hour-glass: the strangulation of time.*
- 25 With the official elimination of the death certificate it was no longer necessary to fabricate witnesses.
- 26 **He wore the words of his victims as a transparent shroud.**
- 27 *I trust V. He is voluminous and speaks of nineteenth-century authors.*
- 28 Christa Wolf and Kleist *No Place on Earth*: as if one's own mind was placed in another's head. As a membrane deftly inserted between the inside skin of the forehead and the outside mucous of the brain. That is as if the bone of the skull had been removed: concisely, in the mind of a woman.
- 29 *G.'s face makes antiquity transferable.*
- 30 The sound of rubber tyres over a Berlin snow. He stopped the automobile to brush the white from the windshield. The pewter eagle flew off the metal car hood and perched on a charcoal linden tree. The rear view mirror reflected the amputated perspective.

31

**Record Hall**

13 rooms, 2 are sealed  
brother to the sister Berlin Masque Building 15  
11 corridors, 2 sides = 22  
1 ladder in each cell  
48 x 9 x 3 x 13

48

— 9

432

— 3

1296

— 13

3888

1296

16848 x ?

AUGUST 1 *The abstraction of numbers is unacceptable. This building brings a sadness on to me. A direct unambiguous structure.*

2

**Problems of Memory:**

One can remember the face but not the name.

"You don't recognise me do you?"

Brought to the surface, then, evaporation.

*"I am terribly sorry, I recognize you but I do not remember your name."*

"Don't worry about it, it's only a signature."

3

The fact of Freud leaving Vienna and of Jung remaining in Kusnacht.

4

The newspaper paragraph announcing the death of Auric: composer of the music for the films *Beauty and the Beast* and *La Symphonie Pastorale*. The same story told in different ways, the love for a woman by a monster.

5

In 1936 the iceman produced the ice blocks 1' x 1' x 1' and delivered them to the house. He dug the steel prongs into the sides of the cubic volume lifting it off the icewagon (pulled by a horse) and put the block into the apartment's wood ice-box. He wore an apron made of seal skin and carried a burlap bag over his arm. He jabbed his ice pick rapidly into the block of ice so that small pieces fell into the street. He picked up the pieces and offered them to those who were being taken away.

6

**The Grandchildren blaming it on the Grandparents.  
All the ingredients for repetition.**

7

*"Did you know that after the divorce years later she married the priest who married them."*

8

The thought of pointal linkage of structures. Possibility of 3 point touch. In another direction all structures are exact distance from every other (100', 200'??). Within site a grid is laid out for the planting of the evergreen forest, very young trees, 3-4 feet high. It will take a long period of time to reach full growth. In the beginning structures will be taller than the trees. . . ground is always earth and should remain that way. The walking through a pine grove on earth.

Structures are placed in site (incremental growth - one at a time over a long period).

The sparks from the electric trolley line and cable spurting against a tableau of pine needles.

The trees (Nature) are planted in a strict order (grid) but their organic form is different (growth). The structures (building) are placed in disorder but their fabricated form is similar (construction).

9 *N. escaped three times:  
Russia, France, America  
Strange that he didn't relate his exile to his collection of butterflies.*

10 **A rollercoaster structure made of wood or made of steel is like the difference between drinking milk out of a bottle or out of a cardboard container.**

11 Room for Thought: inconceivable specifications  
All structures must touch at a point.  
All structures exact distance to a point.  
watchrepairmanstructurebasedonthewhip.

12 I first came to Berlin through a morning fog out from Oslo. The flight attendants were all men, they carried fire-arms. It was a time of terrorist activity. The airports had photographs of those known, some had red crosses covering their faces.

13 **As if it still existed –  
the undertakers finished with it some time ago.**

14 *The constant reviving image of Juan Gris' face at the end. He painted his pallor into his last works as mortifications.*

15 **Fistula:** Open wound  
sends out roots like Medusa  
instead of exterior snakeheads  
interior abscesses

16 Passport implies a dual promise:  
exit & re-entry, departure and return.  
(State validation).

*"How long do you intend to remain?"  
"Until it is all over."*

Located vertically in each corner of the Passport Building's room is a hollow steel tube (8' high). At the top is a 100 watt bulb screwed in.  
The Passport disappeared along with the reality of the photograph. It looked just like him. When it was returned it was completely stapled closed. The irreconcilability of the photo, of the number, of the signature and of the after-image of him.

*With her nail file she pried open the staples.*

17 Passport and isometric maze. P.E. has passed through the isometric plan before. "In what way?" He became caught in the linear web but cut a path. The Lancaster-Hanover Market did not see the earlier connection. The moment the walls are added making it a cell or a series of walled cells, the program of the Passport Building pushes to the surface. The isometric investigations of the Diamond are pivotal. The cellularisation specialises. The 9 square isometric plan simply eliminates a centre.

18 *Ariadne's ball of string originating at the centre of the labyrinth-maze in order that she can return to the labyrinth. Before entering she knew that the Minotaur had already died.*

19 D.S. telephone call coincidental,  
his thoughts on the New England Masque  
are an uncanny parallelism.

20 My Grandfather was a surgeon in Paris during that period of time you referred to. He collected Légers for a strange reason: he claimed that at the exact moment of the death of his hospital patients their eyes gave off an expression duplicating the eyes of the women Léger had painted. Paul was offended by the observation and said so. He was invited to see for himself. To add to the offense my Grandfather stated he even had seen Léger in a tuxedo. That remark broke off their relationship for good.

21 *Gentrification has a direct relationship to poverty.*

22 **For those who looked the other way.**  
He/She in a capsule (rectangular) in the centre a viewer (a modified sub-marine telescope). The viewer sees projected on a mirror screen his/her own face. No matter how the telescope syringe shaped bulb is moved, the face of the viewer can only be seen, yet outside of the capsule, the people in the park can look up into the mirror and see themselves and each other along with the centralised image of the internal viewer-observer. Simply put, the interior observer's face on the mirror is surrounded by a multitude of passing faces he/she is unable to see.

23 The Toll Taker moves around the park, collecting tolls, announcing tolls. Tractor wheels, T.V. antenna, loudspeaker, periscope and a large post office mail collection bag are attached at the back of the vehicle.

24 **Judge:** **Mirror image:** *not quite.*

25 *Sense of relief: project drawing to a close.*

26 "Dental work is not mathematical, it is an art. When tapping your teeth I changed the numbers in you. Not to trick you but to test you. I had a neurologist come in and he insisted I drill teeth that were in perfectly good condition. On the fifth tooth (the one he thought was OK) I found decay."

27 **Plumber's quarters:** Bunk bed suspended  
A plumbing unit  
Toilet  
Shower  
Sink  
Cooking unit in corner  
Flue to outside  
bypasses rain water cistern

Plumber insists on getting back skin. He wants to clean it inside.  
Outside shelf, Edison phonograph.  
After his daily ritual shower he leaves the unit, still wet, and cranks the phonograph. He always receives a shock.  
He copied the unit from the design of the Master Builder of the Lancaster-Hanover Masque. The Master Builder remembers showing him the Berlin Masque. The Plumber knows about waste.

28 *Started drawing of Record Hall, the heat in New York has reached 98° degrees Fahrenheit. Tons of air conditioning heat pouring into the air, engulfing the city.*

29 From *Search for a Living Fossil* by E. Clymer. Scientists were startled more than a hundred years ago by the discovery in England of a 250 million year old fossil fish. Such a fossil had never before been brought to their attention. The ancient fish had strange leg-like fins that were supported on hollow spines. Louis Agassiz, the great Swiss geologist, named it Coelacanth (see-la-kanth) after two Greek words meaning "hollow" and "spine".

30	<i>Enemy of the State: The Long-Distance Runner.</i> <i>Obscenity: Resurrection of Old Dreams.</i>
31	<i>To cover the site</i> <i>with whispers</i> <i>6" above the Earth.</i>
SEPTEMBER	I once observed a man out at night with a vacuum cleaner held high above his head trying to suck in the stars: it was a hopeless task. He didn't have the machine plugged in.
2	The skylight/lightwells of the Record Hall are translucent.
3	<b>Nature:</b> The leaving of the shed locust shells on the Oak trees waiting for a September wind to blow them off "We built the damned pool in the lawn ... can't be used since the snails arrived."  Once you cut a trumpet in half through the long axis there is no sense if trying to put it back together again the sound won't be the same ... ever again.
4	<i>Out from Lampasas to Odessa</i>  <i>The rocking chair is the soul of the porch remove it and all you have left is white pine for the carpenter ants.</i>
5	"I have never seen a cat stalk a bat. Have you?"  <i>The problem of duality.</i>
6	<b>The photo of Gris in a tuxedo.</b>
7	<i>The conversations of Mendelsohn and Einstein about the tower.</i>
8	The haunting atmosphere of certain neighbourhoods in Berlin during the Fall. The organ music preventing the black eagle's complete entry. The grey suede spats worn by Behrens.
9	<i>Dr. K expertly removed the bone from the flesh and asked that his glass be re-filled.</i>  <i>M. adjusted the needle and said she wanted to dance.</i>
10	<b>The sound of one's language being desecrated. (In the short run) (Short circuiting)</b>
11	The analogy of the serpent and the decapitated angel head (with wings). It is the missing parts that confound, the initial shock prevents filling in.
12	The Mimosa tree in August weeps white-pink blossoms.
13	<i>Tragedy of the Coelacanth caught.</i>

14	Parody:	Attempted cerebral murder they want the body to still-walk (for a while)
15	She sealed his coffin with the nails of his mind unbeknownst to her her hammering announced his thoughts immortality	
16	<b>Berlin Graffiti</b>	<b>Political Anticipatory Issues</b> New York Graffiti                      Social Hopeless Signatures
17	<b>Hybrid Landscape:</b>	<b>12' high chain link fences surrounding 5th Avenue Apartment Houses... to the property line.</b>
18	<i>Investigation of A Museum</i>  <i>The granite pharaohs plotting their own escape from the museum the pewter Ibis gliding through the Egyptian hall fluorescent marble panther leaping on the glass faun shattering it to shards. The ivory snake blood-stained by the slivers The painting on Nefertite's face blistering as hyenas suck her wax tits The flesh of man a sacrilege in such a place.</i>	
19	The kidnapping of a voice how to drag it out of its organic place meaning of "His voice will be heard no more" precedes: "He will be seen no more". Once the voice is taken where to hide it? Is the voice equivalent to sound? When reading a quote: whose voice do we hear when we say "It sounds like him". Is it his or our own? The terrorist threat "We will sound like you". The victims appeal "Give us back our voice!"	
20	<b>The similarities of a museum and a zoological park at night</b>	
21	<i>When first Ariadne's &amp; the Minotaur's eyes met they recognized one in each other.</i>	

LIBRARY & INFORMATION SERVICE

22	Poetry	Missing Letter (E) Poets calling for return
23		<i>The pieces could be installed on/in site over a long period of time. One at a time. Perhaps, two 30-year generations.</i>
24		<b>R.'s description of E.'s having lost his dreams.</b>
25		The store front sign indicating the training of guard dogs: They can be rented. A discarded white T-shirt stinking of a brutality. The anguish of the soul as the embalming fluid approaches the head.
26		<b>As one proceeds the drawings become starker and the writings more convoluted.</b>
27		Revision of thought on box car. Whole box car to be brought and placed on site. As deconstruction of the box car commences construction of the wall (where the parts are to be placed) begins. No way of knowing in the beginning how long the wall will be.
28		<i>To trace over another's life.</i>
29		When the park closes at night the park attendant dresses the back wounds of the merry-go-round horses due to the cylindrical rods speared through their bellies. They must sleep standing up. In the morning the moisture is wiped off their enamel manes.
30		<b>Impossible to trace over another's line, the thought is missing.</b>
CTOBER 1		<i>School buses have the sense of dread in them.</i>
2		<b>Mask Repairman drives a stair vehicle Motor and driving wheel are under stairs. He climbs stairs to place masks in transparent cells. He repairs masks in his shop behind stairs.</b>
3		The German knights pushed on to Cefalú pulling the painted black wood Pegasus on wheels behind them. The wind blew the lemons off the trees. The evening sea clouds followed the procession along the northern coast. He maintained his bent elbow at an outstretched horizontal position where the peacock was perched. On the road a squirrel passed in front of them. The infected rodent's tail was like a fish bone, picked clean. They felt it a bad sign, even though Medusa's head was in the burlap pouch. The bag was slung over the back of the lead horse. A rain drop mixed with the fluid of the lizard's eye. They passed a row of crucifixions. The only things not in a state of putrefaction was the armour. They all lowered their visors as they approached the town.
4		<i>George related the events of that tragic winter. There occurred a sudden and rapid drop in temperature and the peculiar fact of the Landwehr Canal freezing during the early moments of dawn. Flocks of crows had landed on the canal during the night, completely covering the water. Somehow their claws had frozen into the ice. The sight confronting the Berliners was that of white slabs of ice moving in slow motion within the confines of the canal walls as the birds were frantically flapping their wings. Their legs were being stretched to the limit trying to release themselves from the frozen water which encased their claws. The shock was intensified by the observation that although the beaks of the birds were moving up and down there was no sound emitting into the morning air.</i>

5	Post Stamp?	Disintegration: Stamp Building mechanism and Stamp Bureau. Passport Stamp? Gold - Silver - Dental  Male - Female
6	4 I 4 I 4 I 4 = 19 Even Thought - Odd Number	Troubled Plan clear, the rest uncomfortable Ceiling fan of 1932 Governmental offices

*Your documents please.*

Drawings

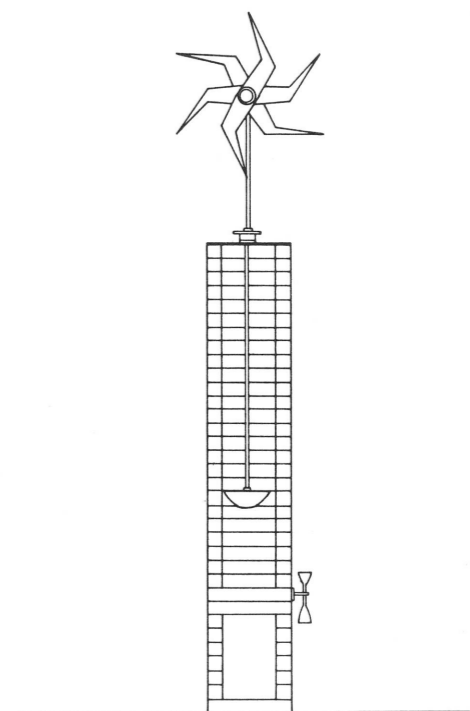
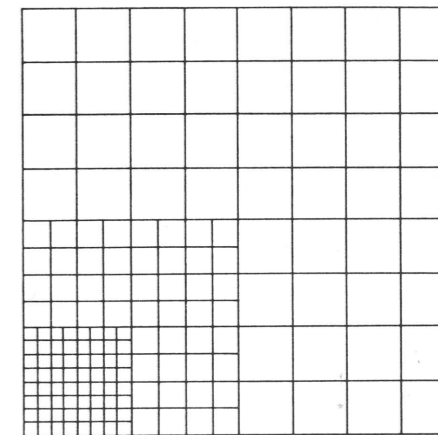
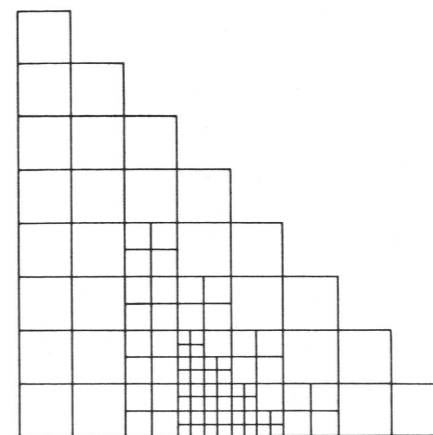

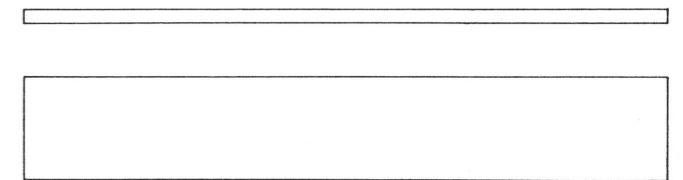
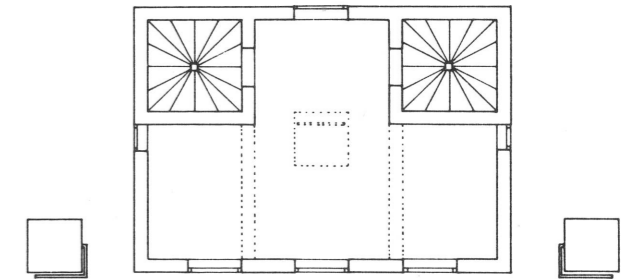
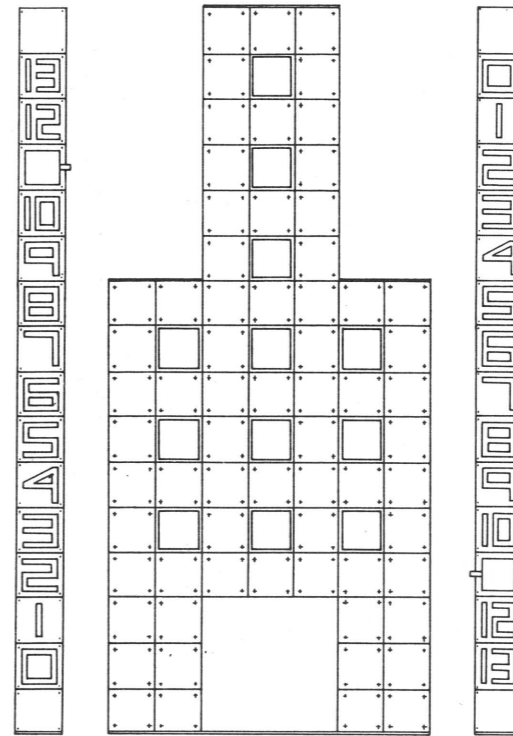
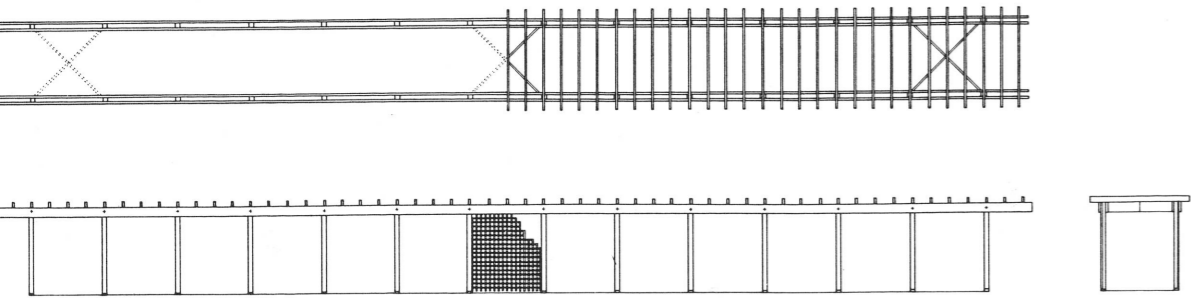
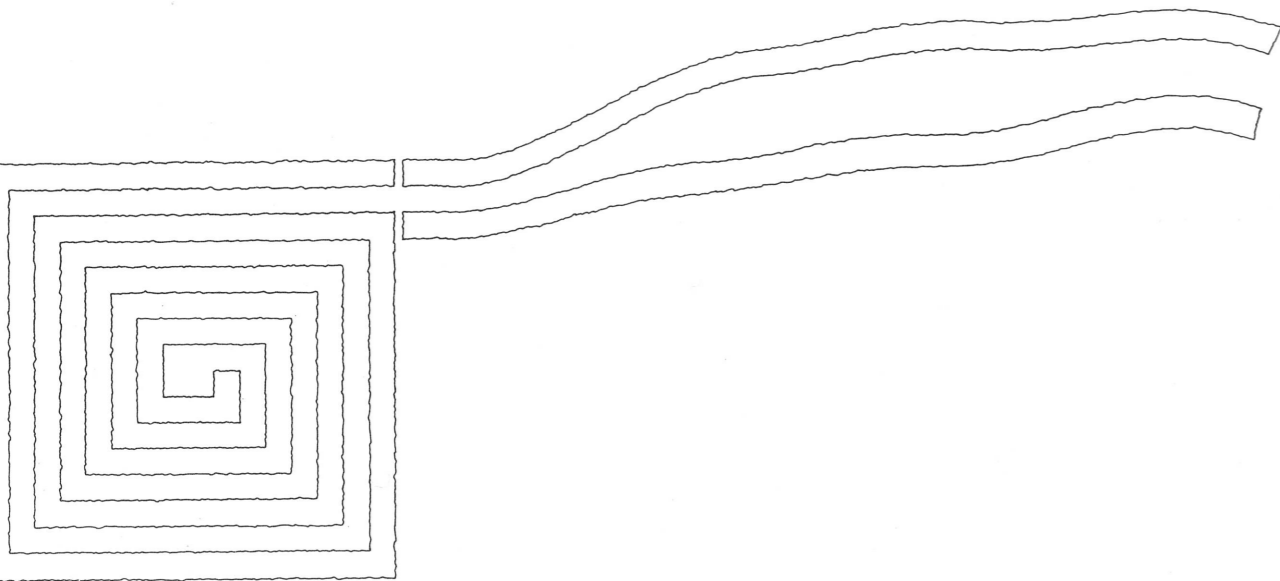



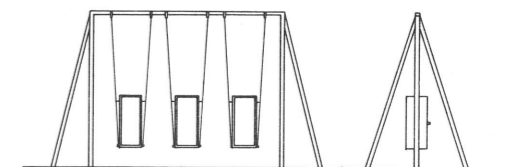
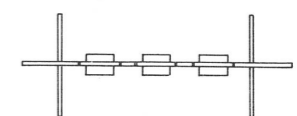
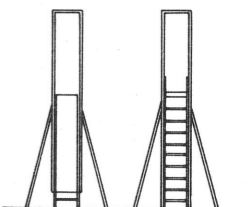
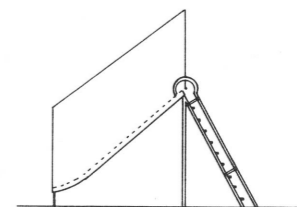
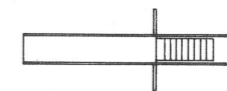
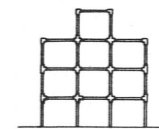
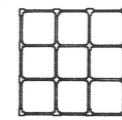
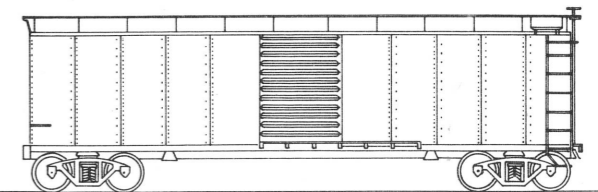
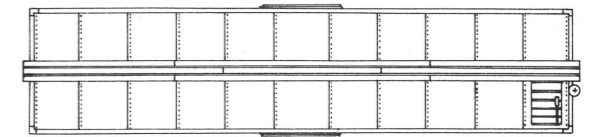
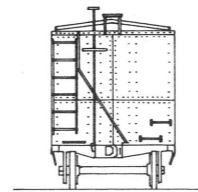
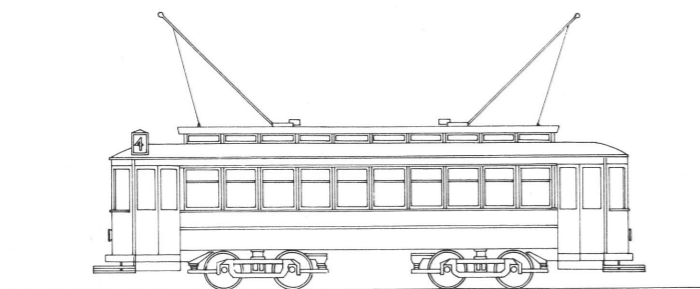
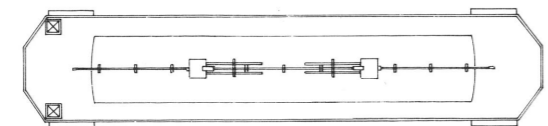
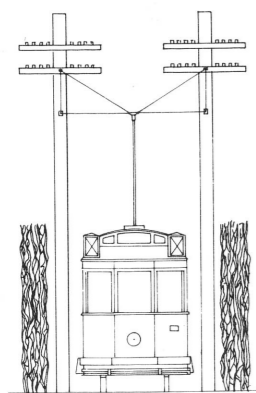
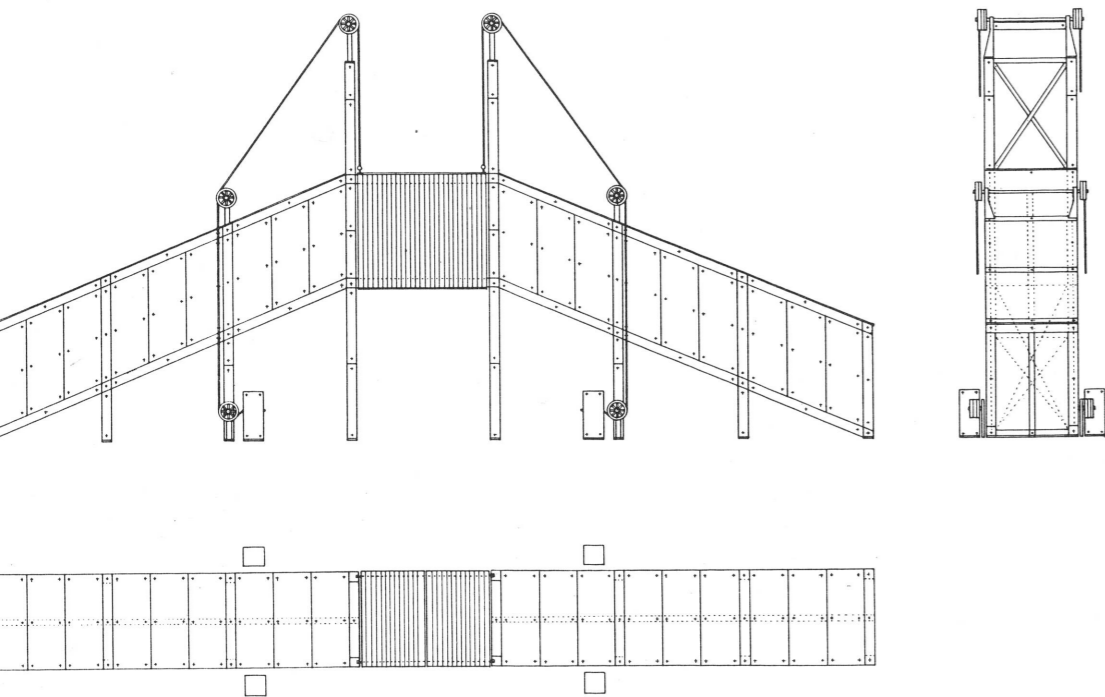

11 Children Jungle Jim

13 Children Sand-Box

12 Children Sliding Pond

14 Children Swings

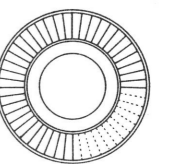
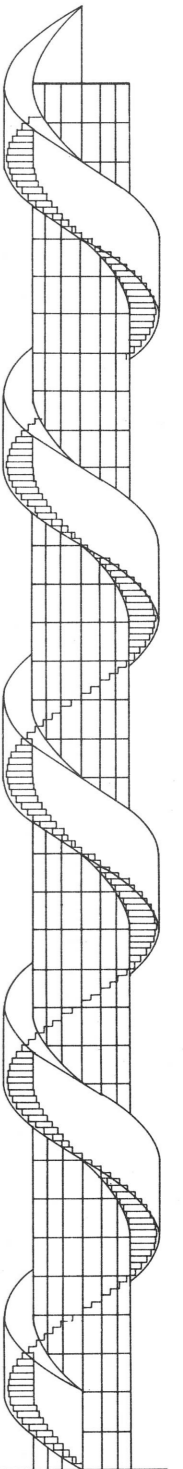
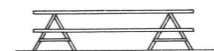
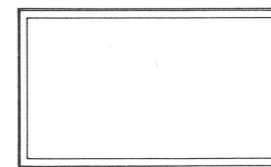
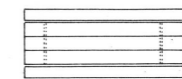
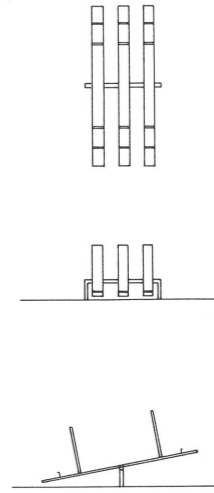
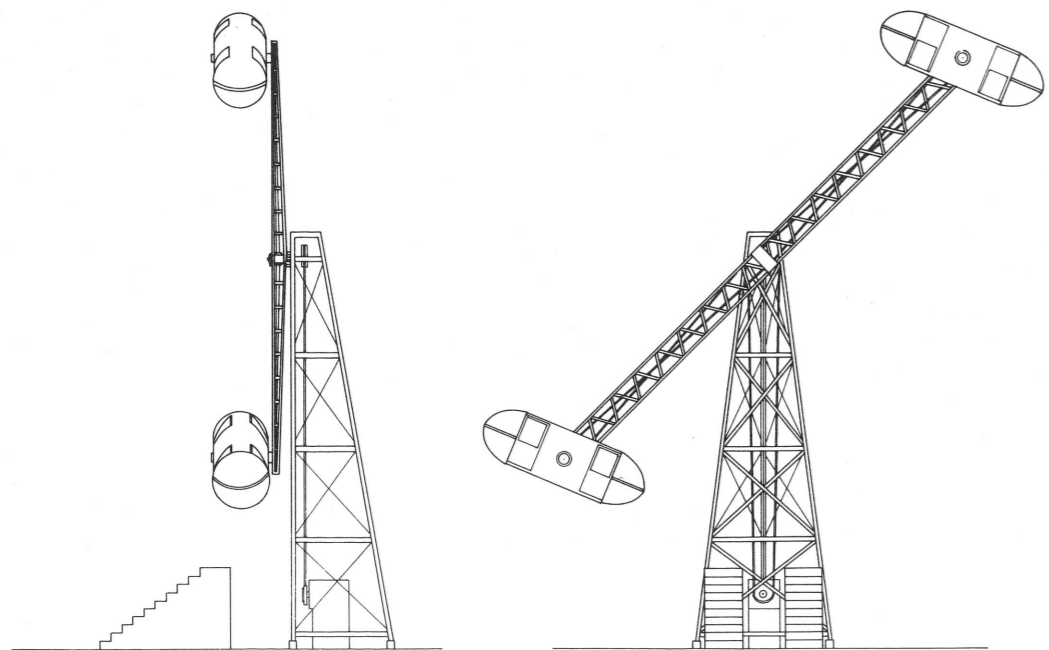
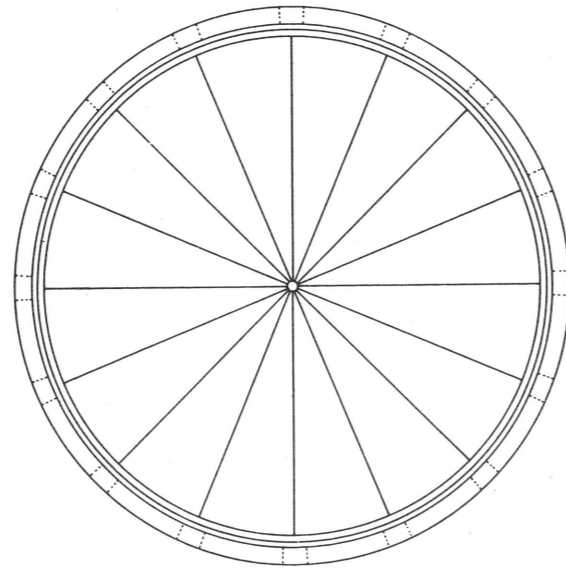
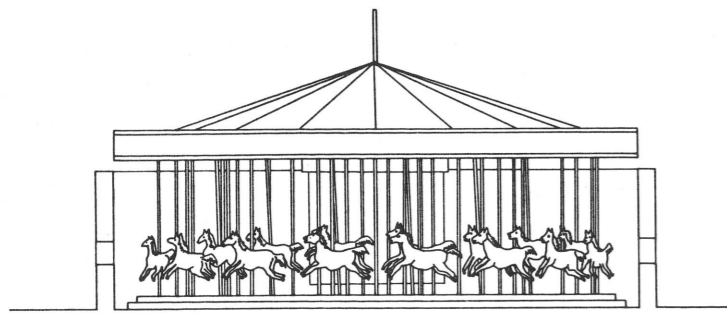

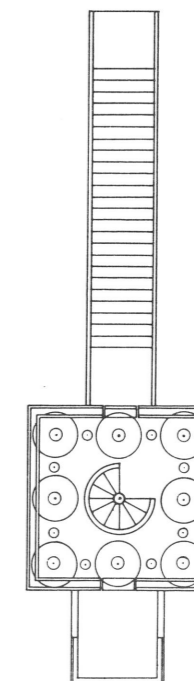
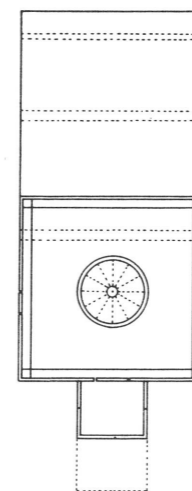
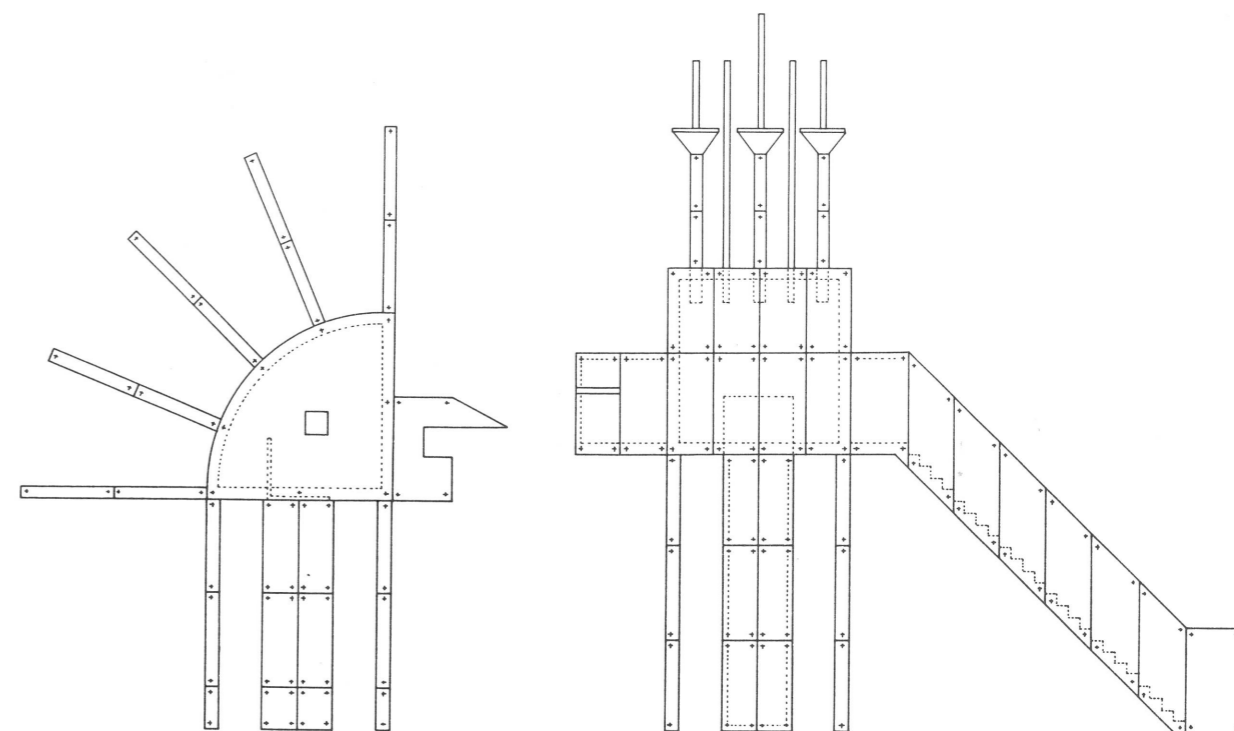
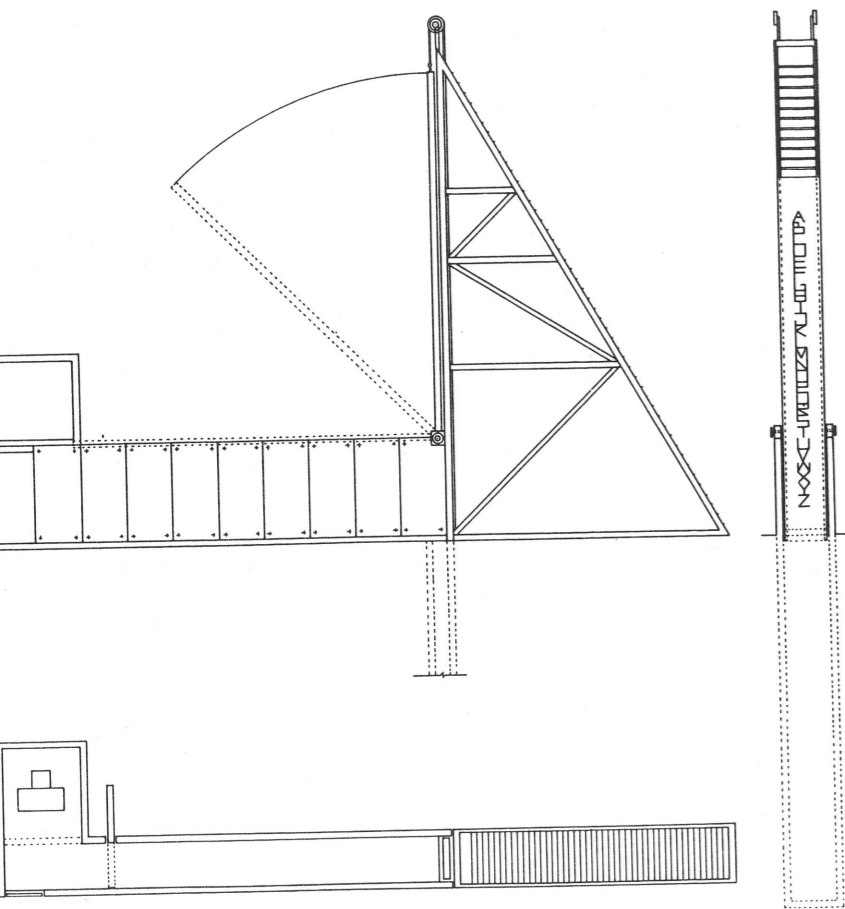
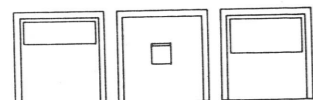
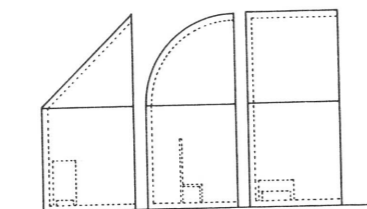
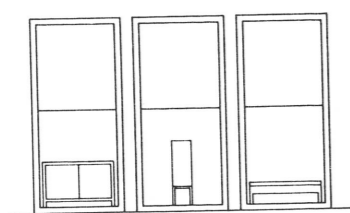

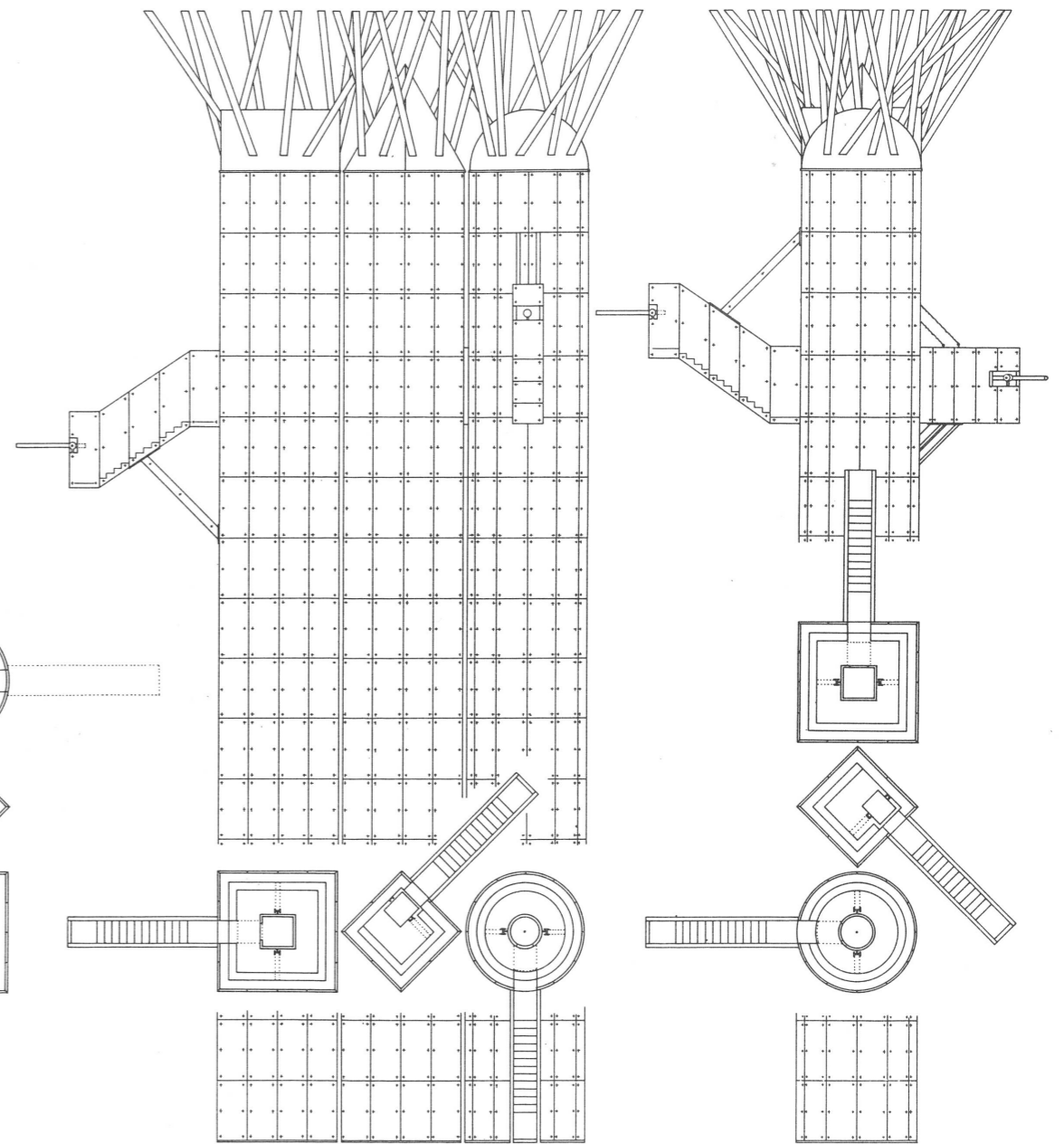
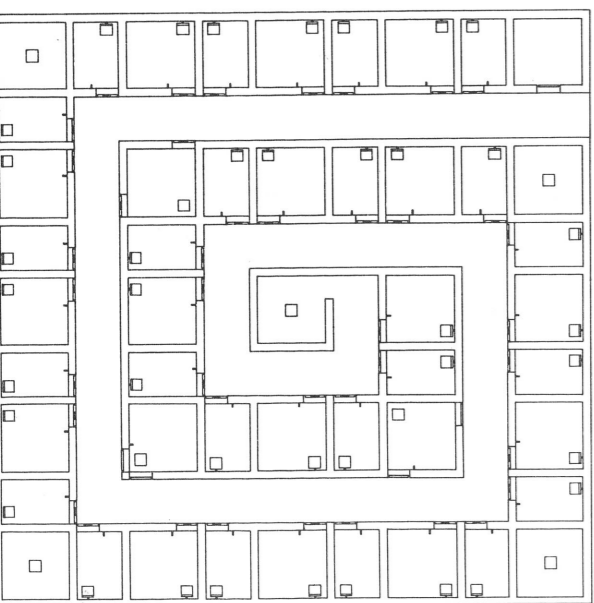
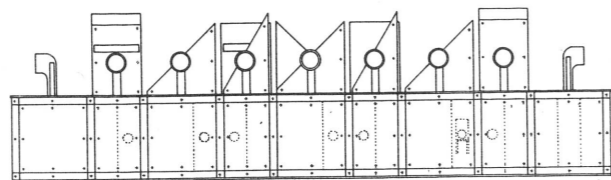
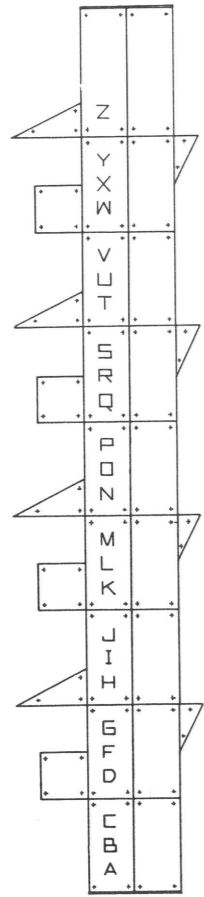

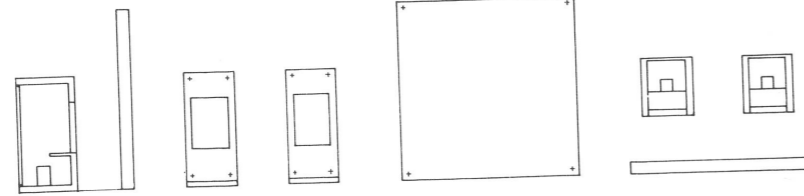
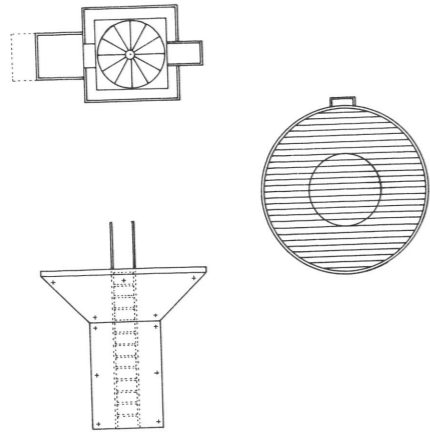
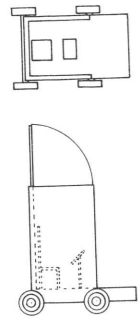

29 Typesetter - Type House

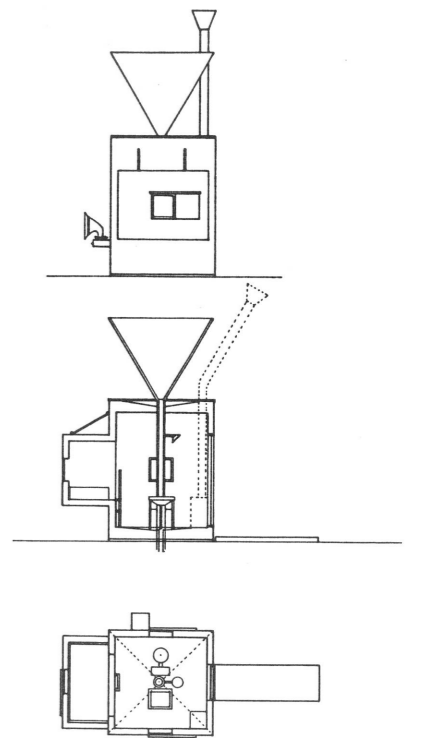
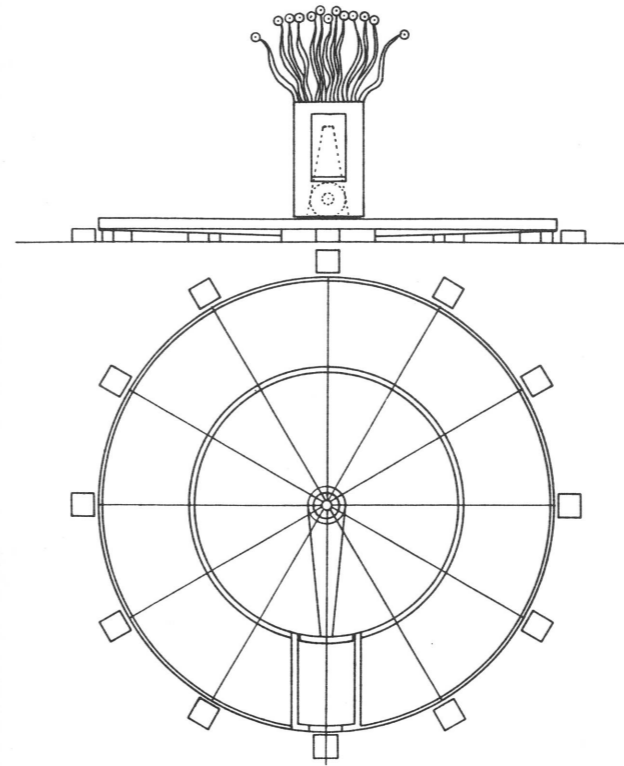
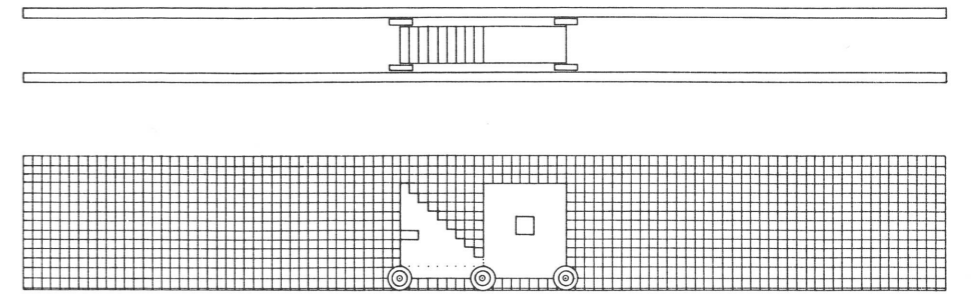
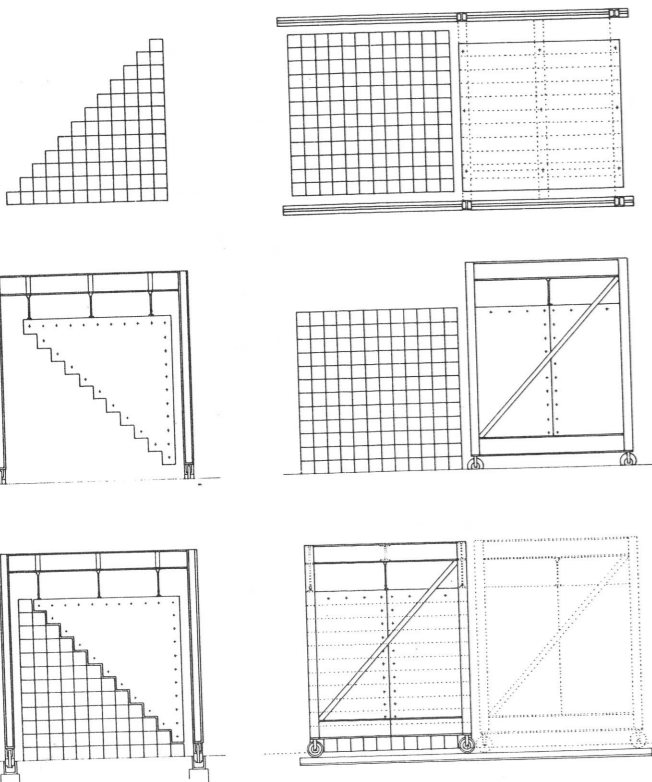

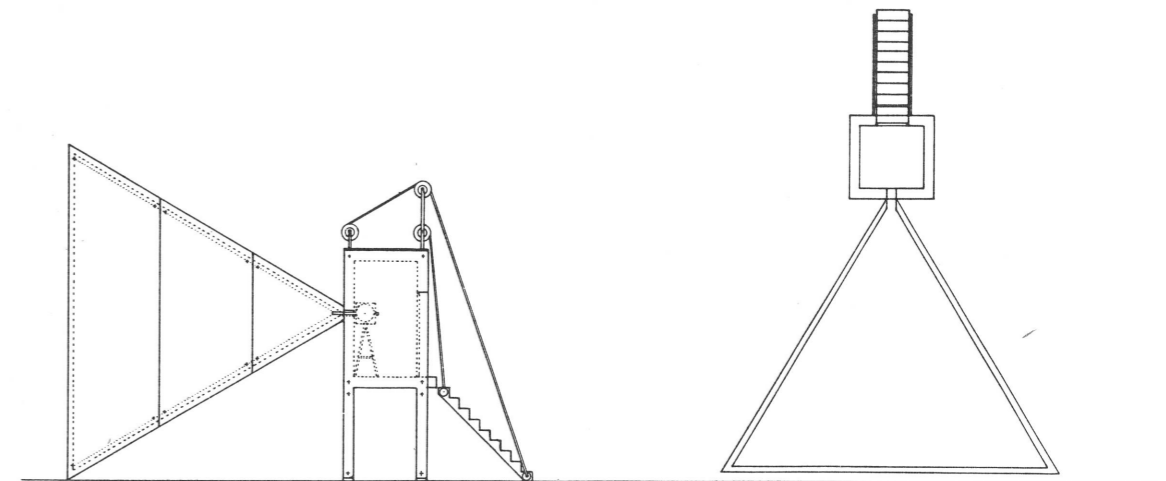
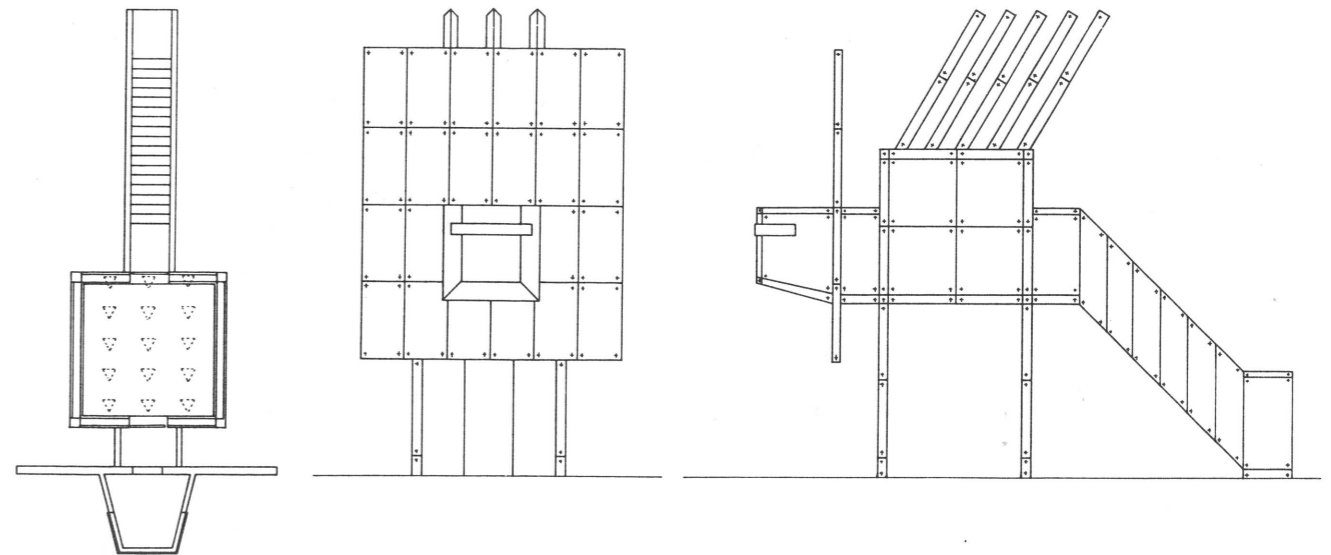
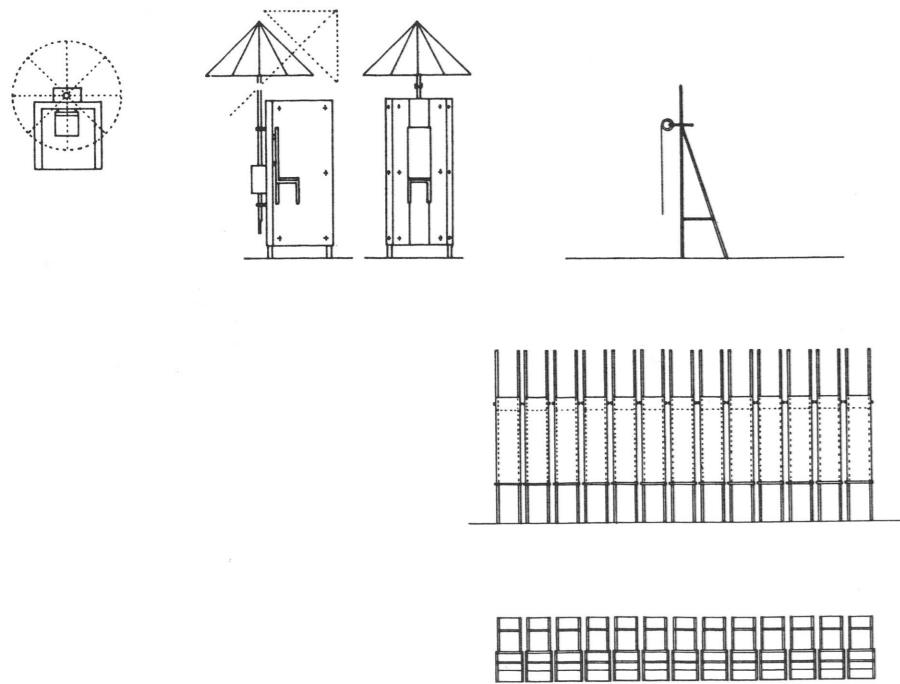
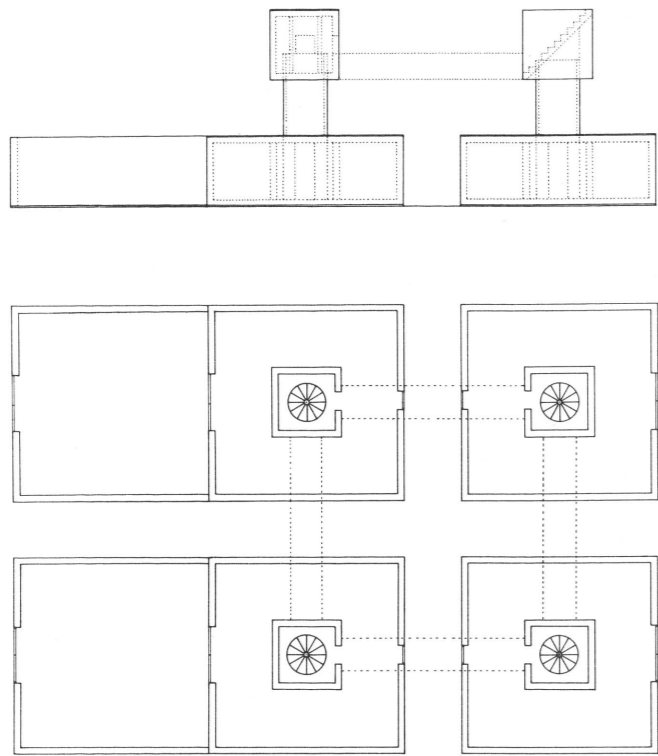

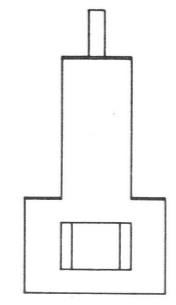
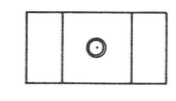
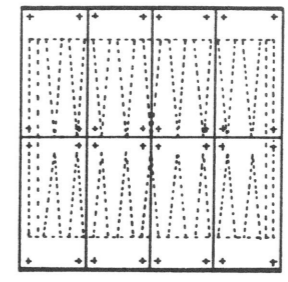
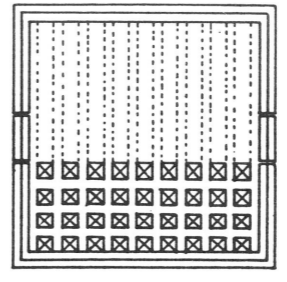
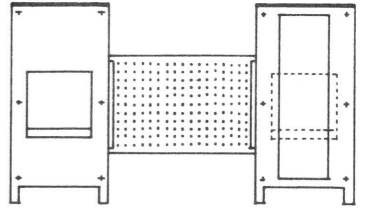
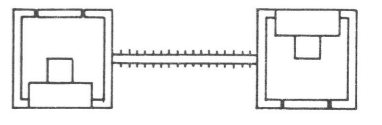
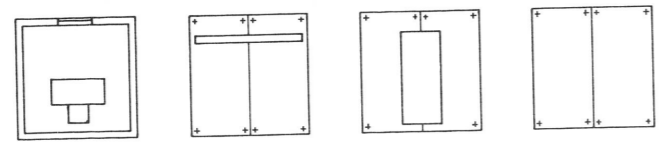
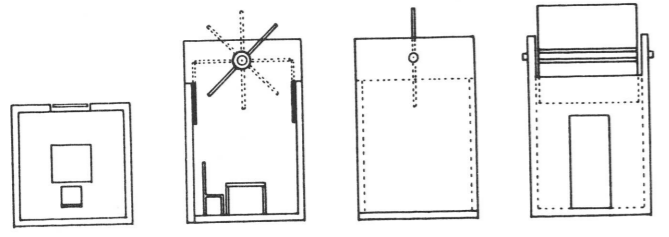
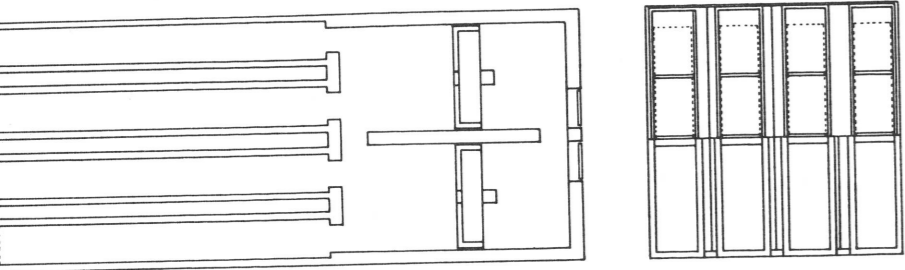
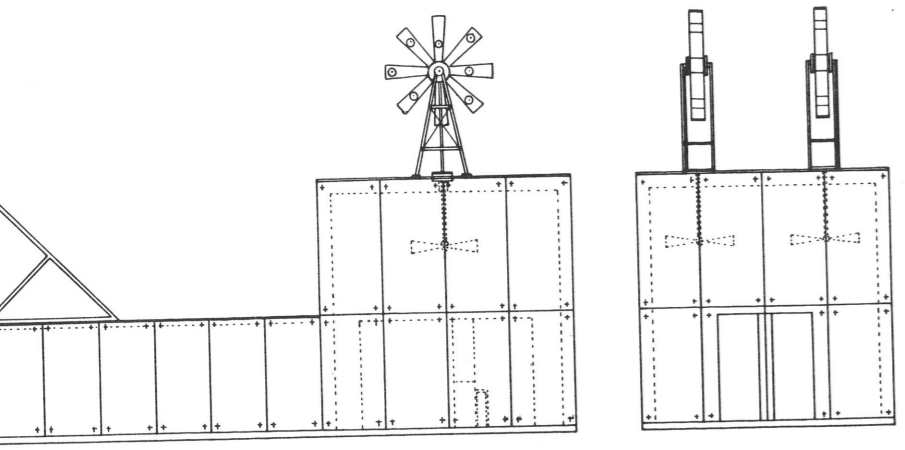

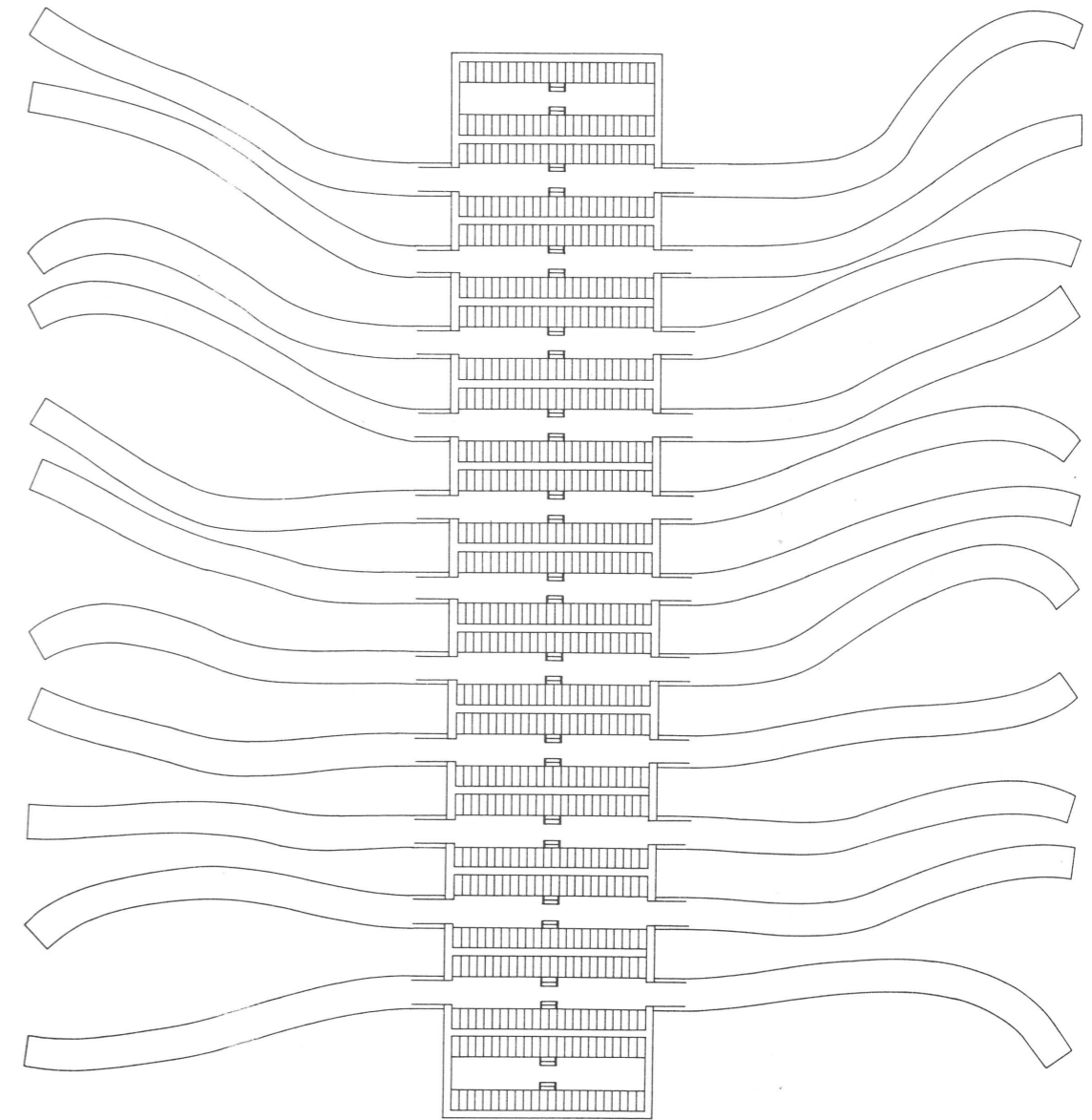
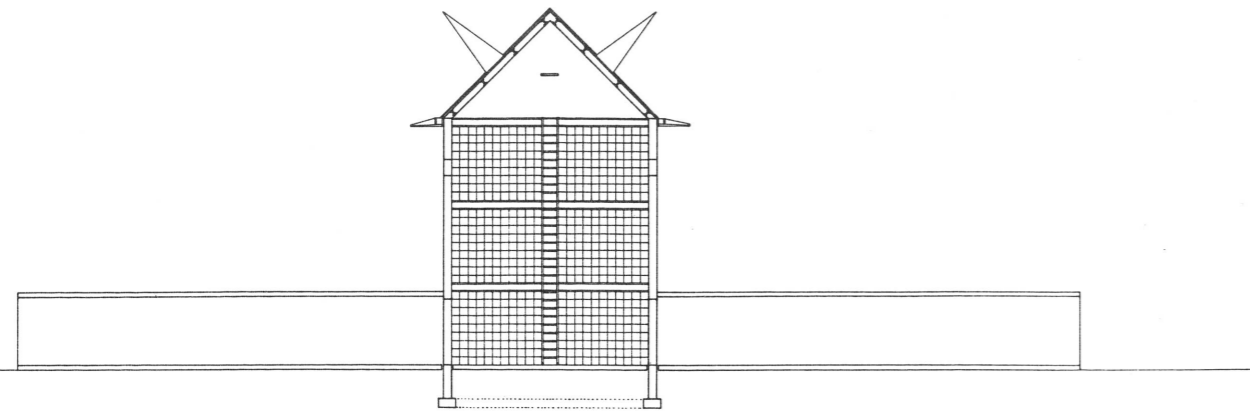
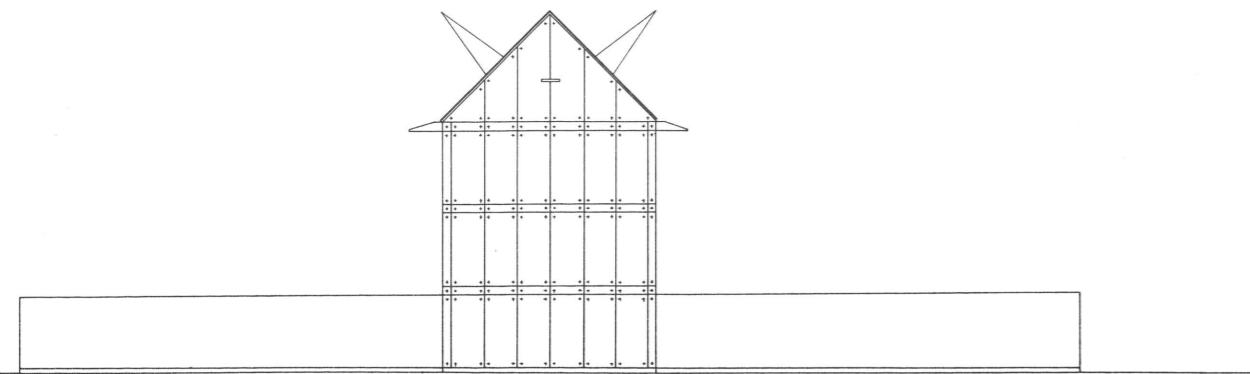
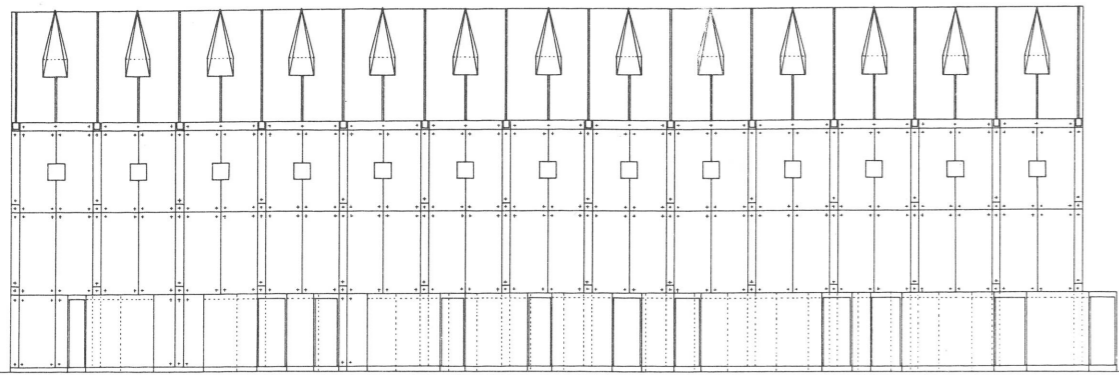



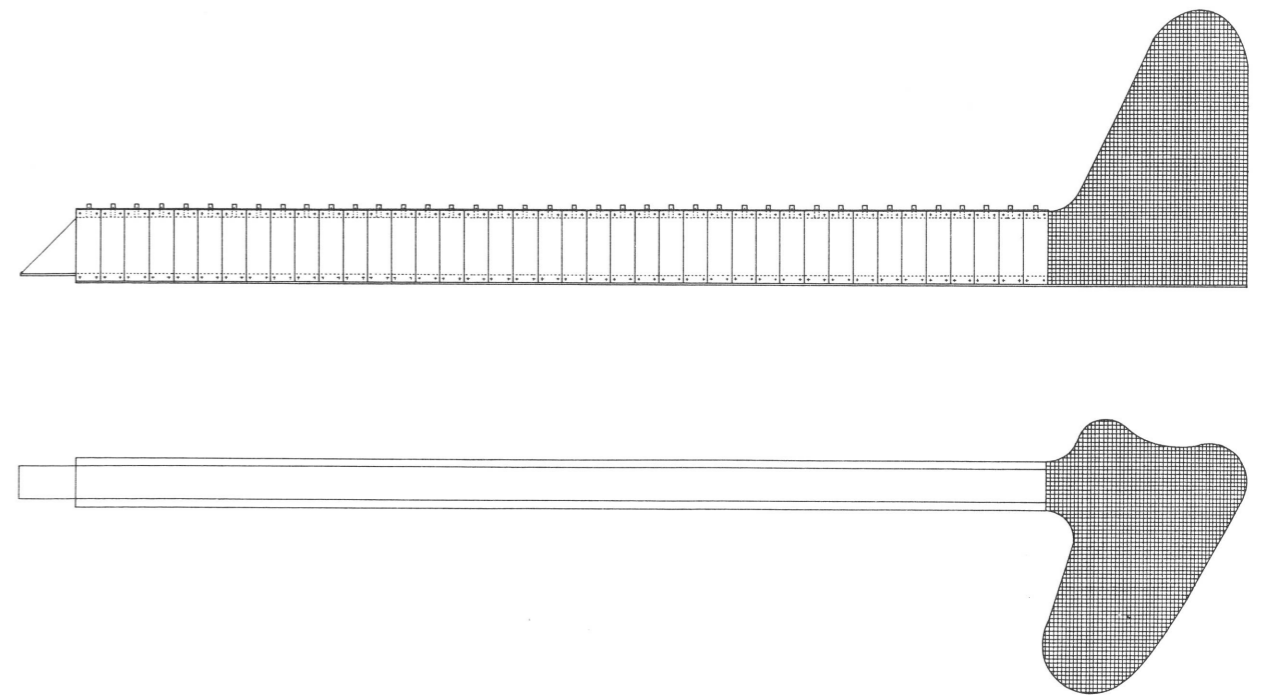
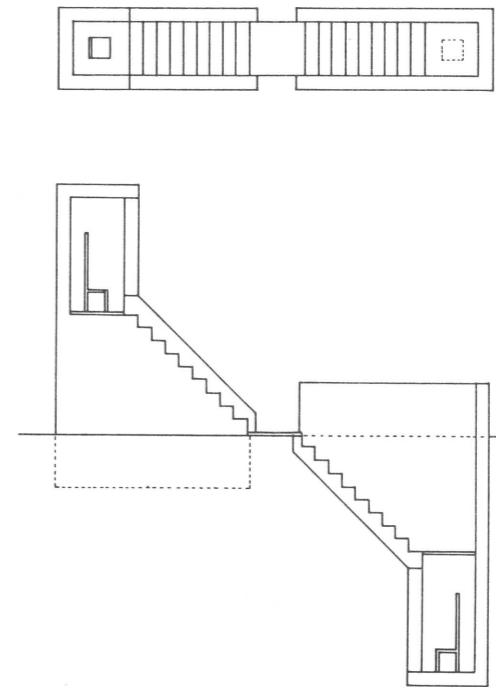
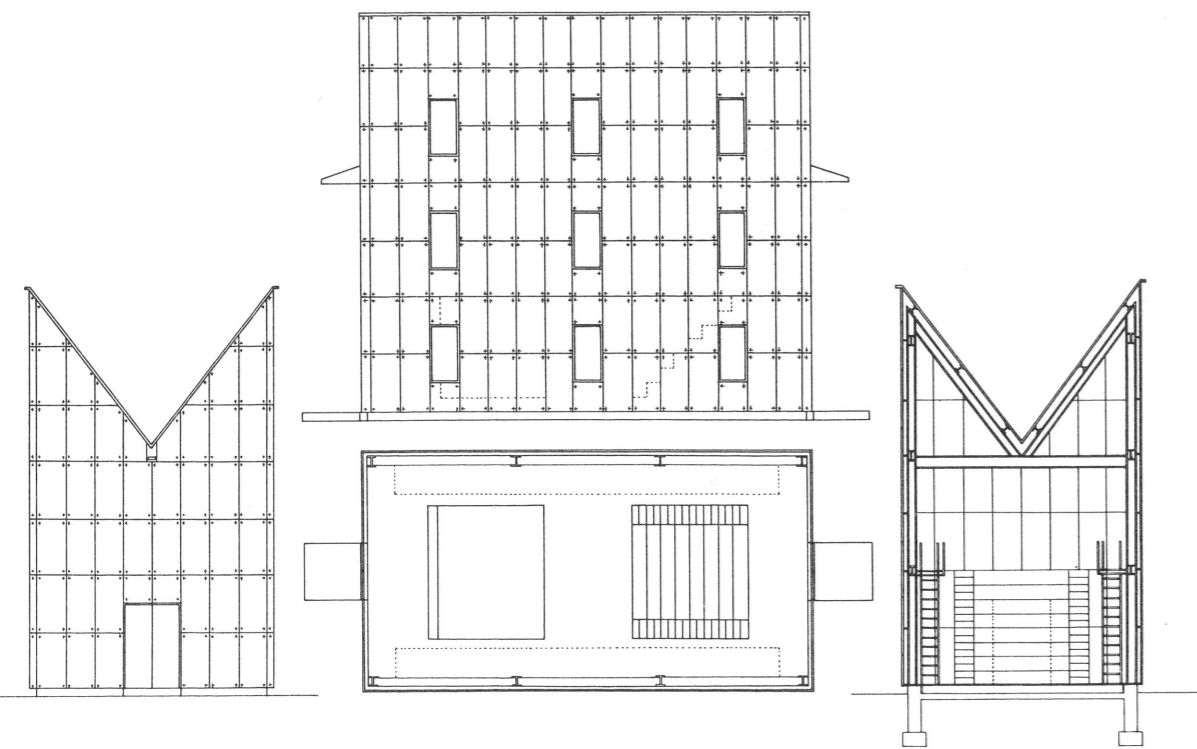
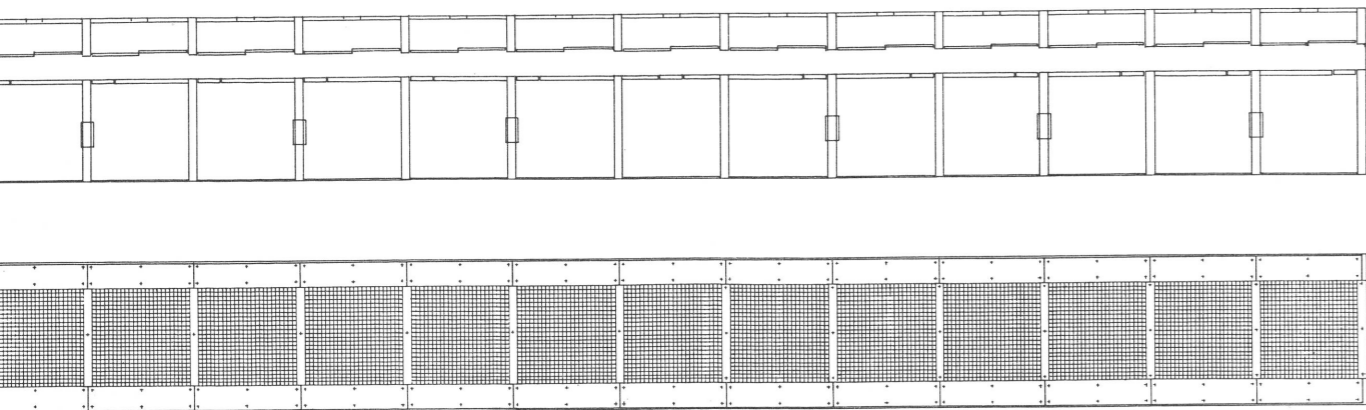

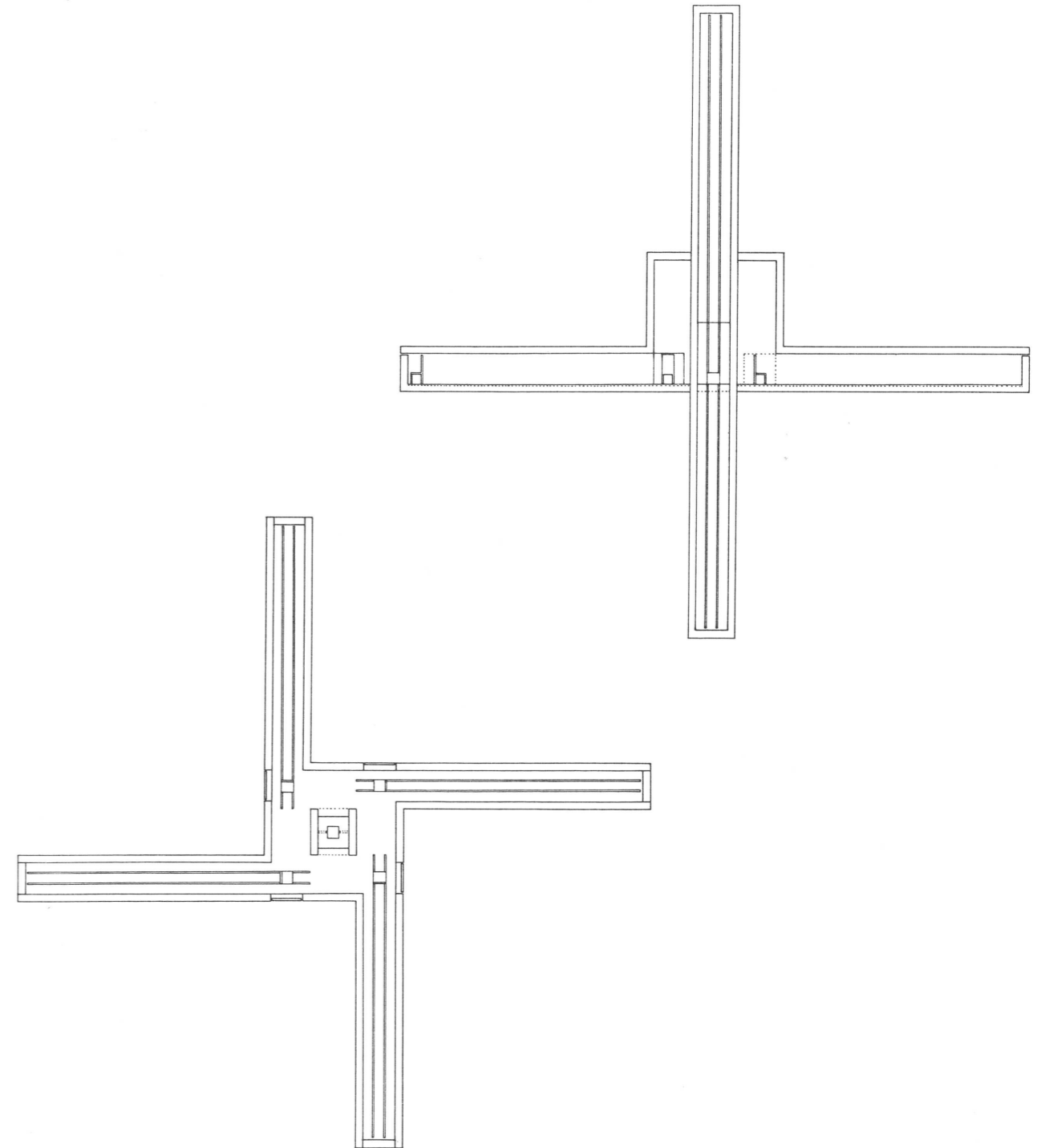
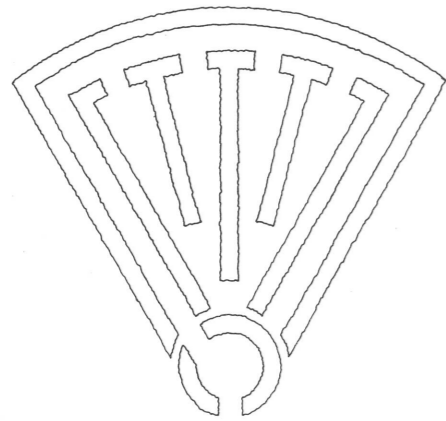
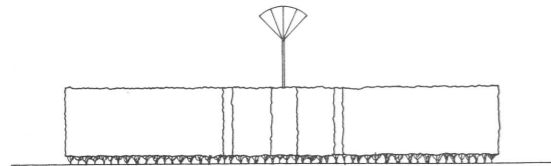
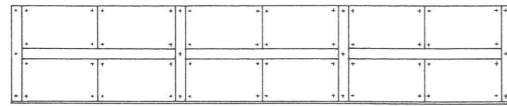
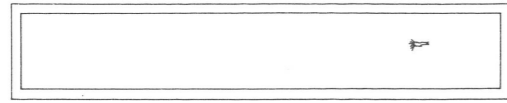

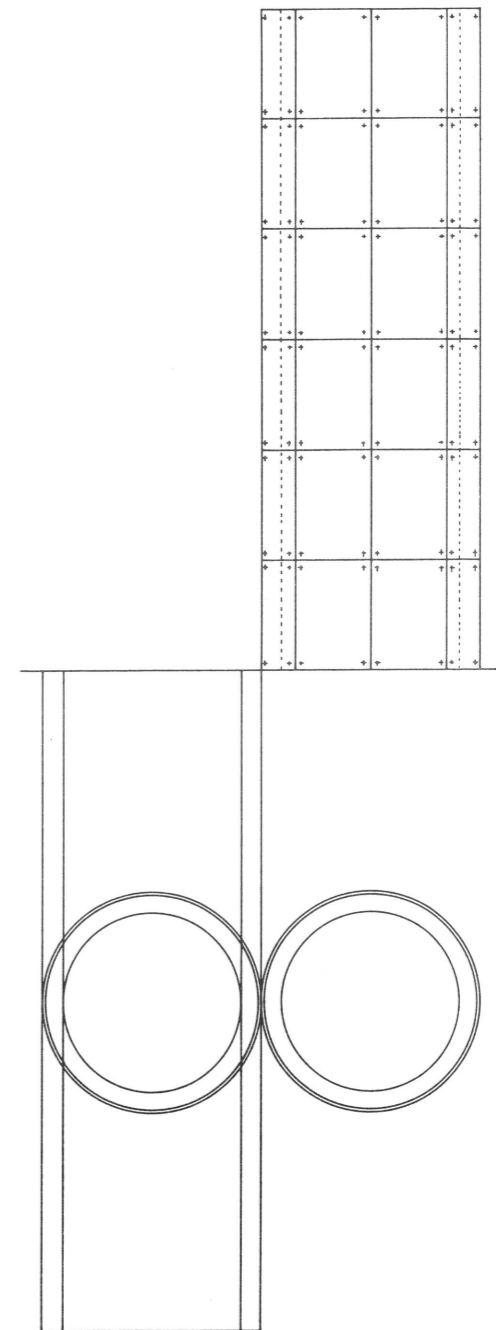
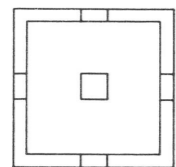
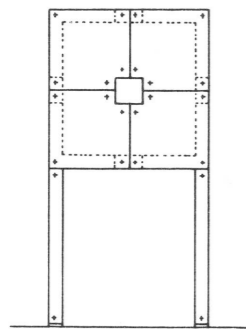
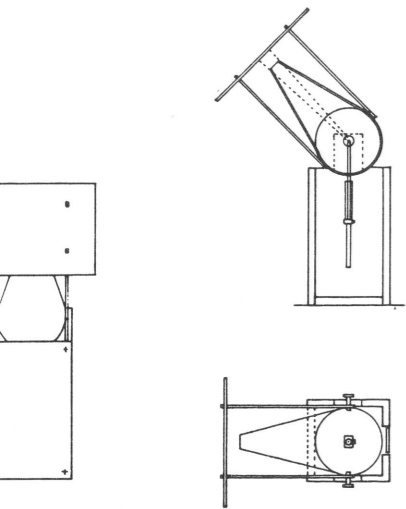

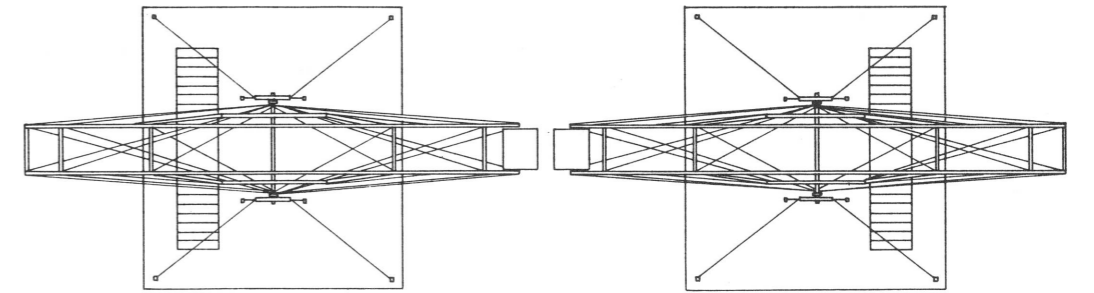
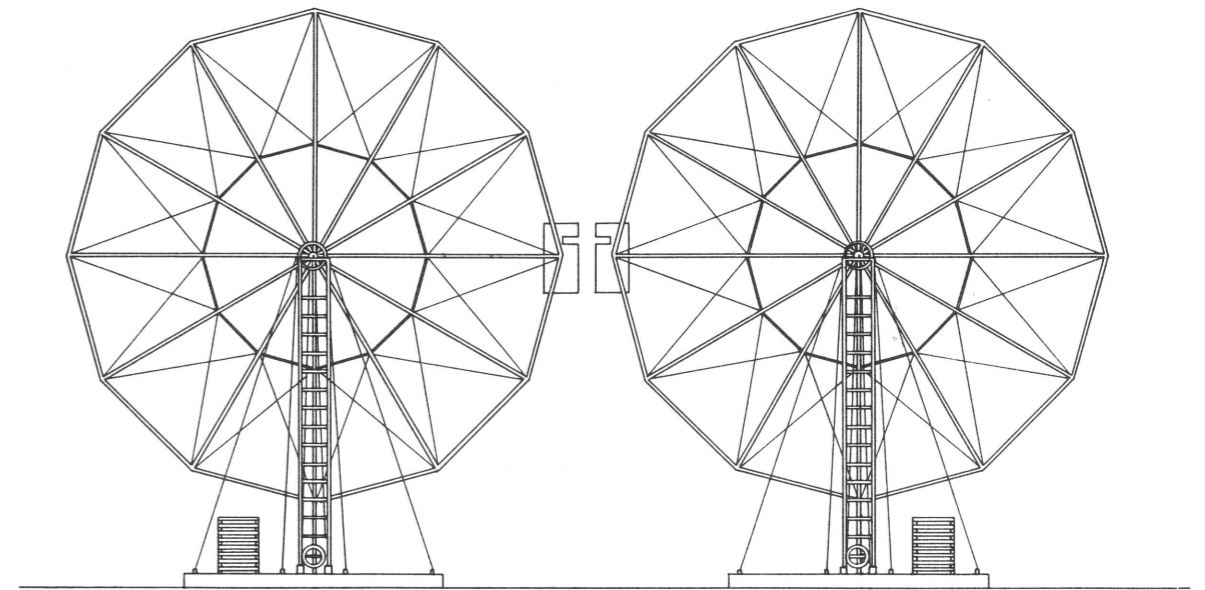
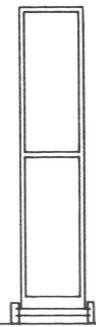
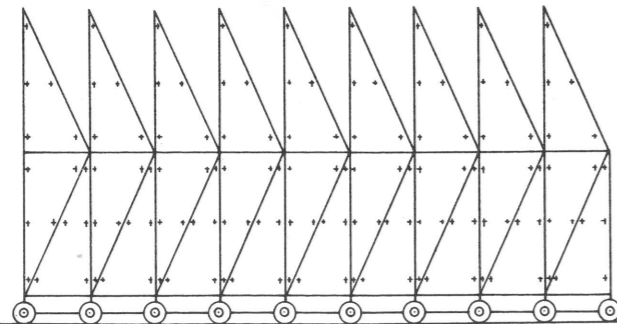
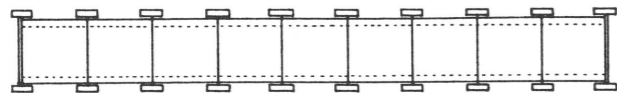
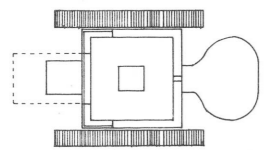
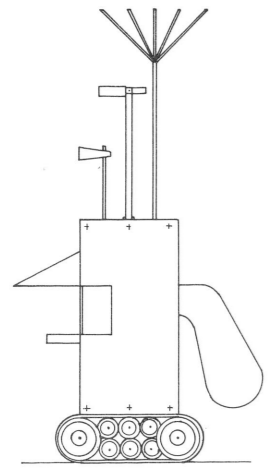

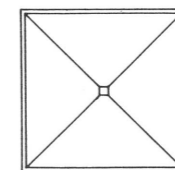
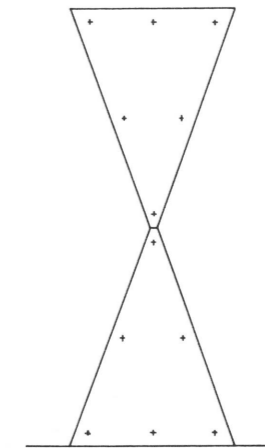
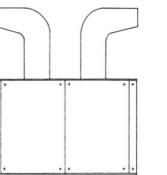
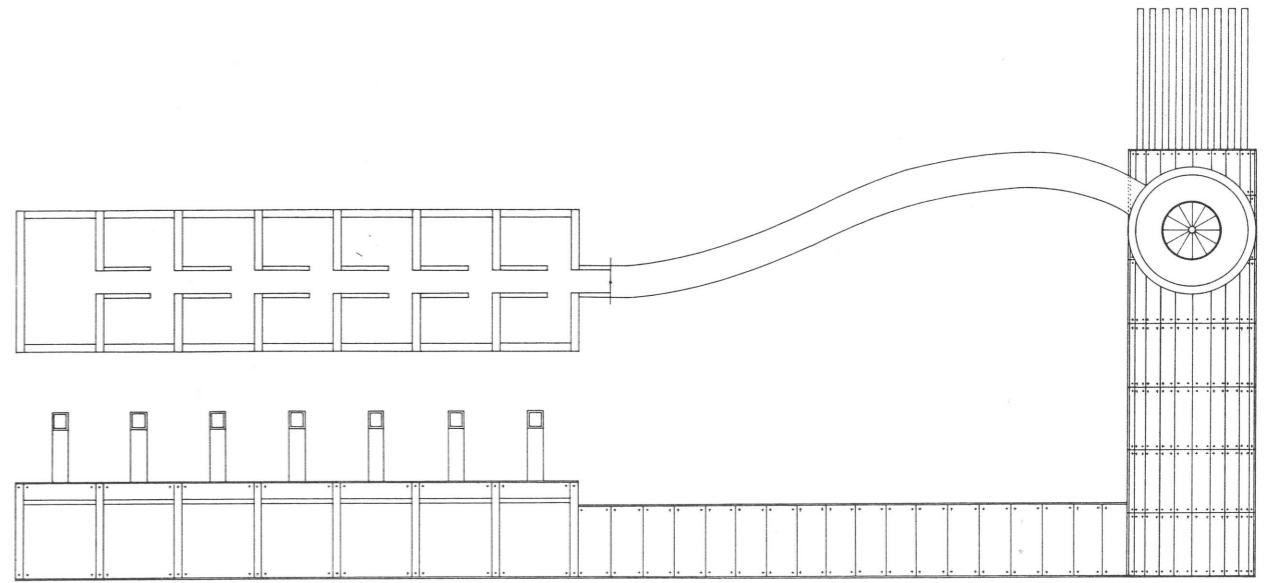
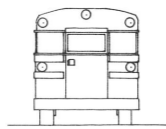
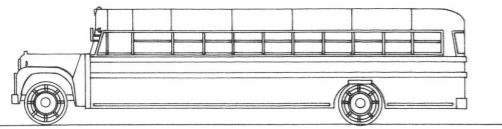
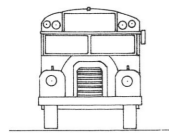
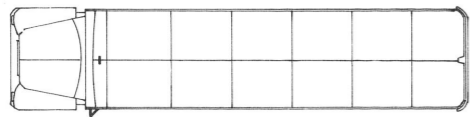
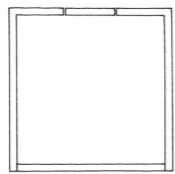
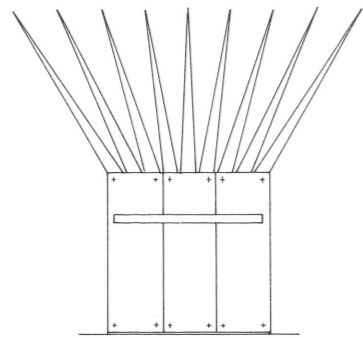

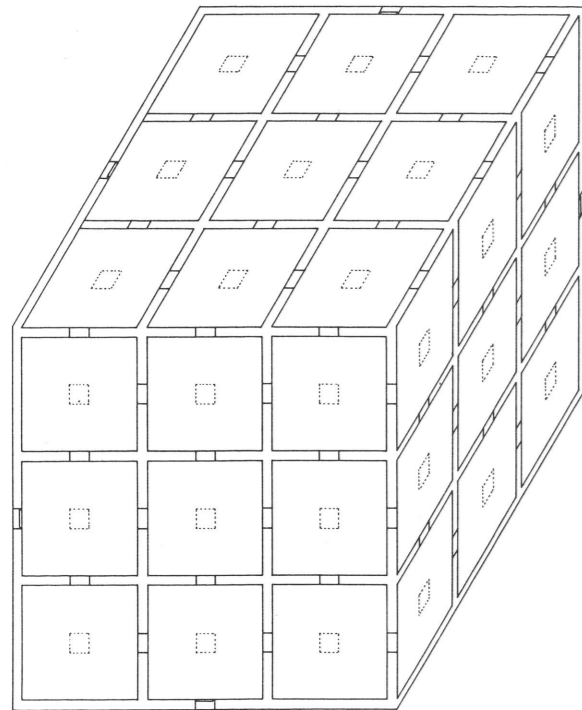
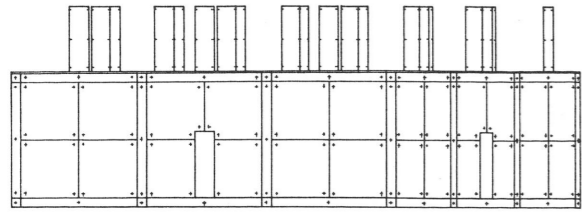

Sketches

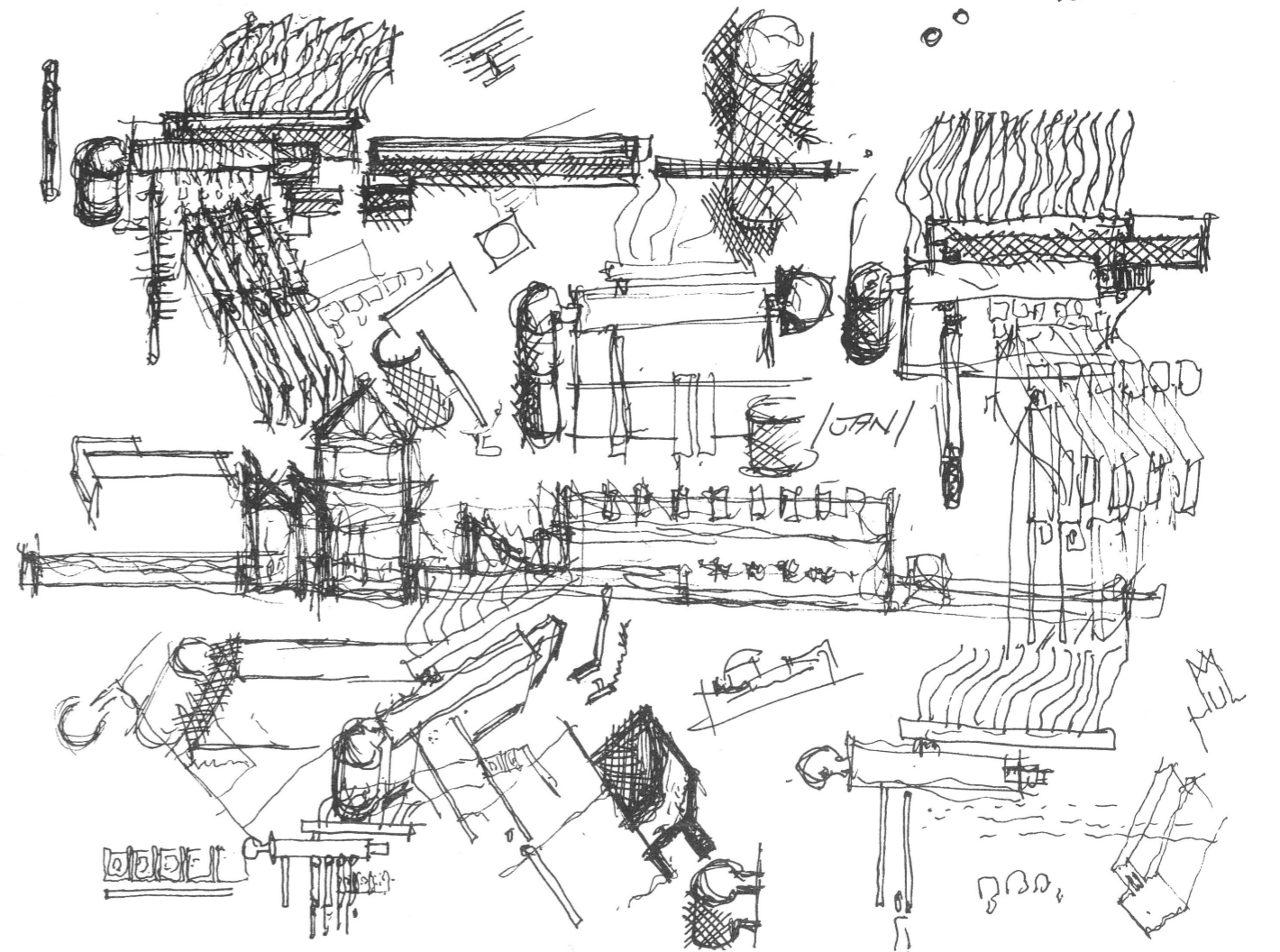
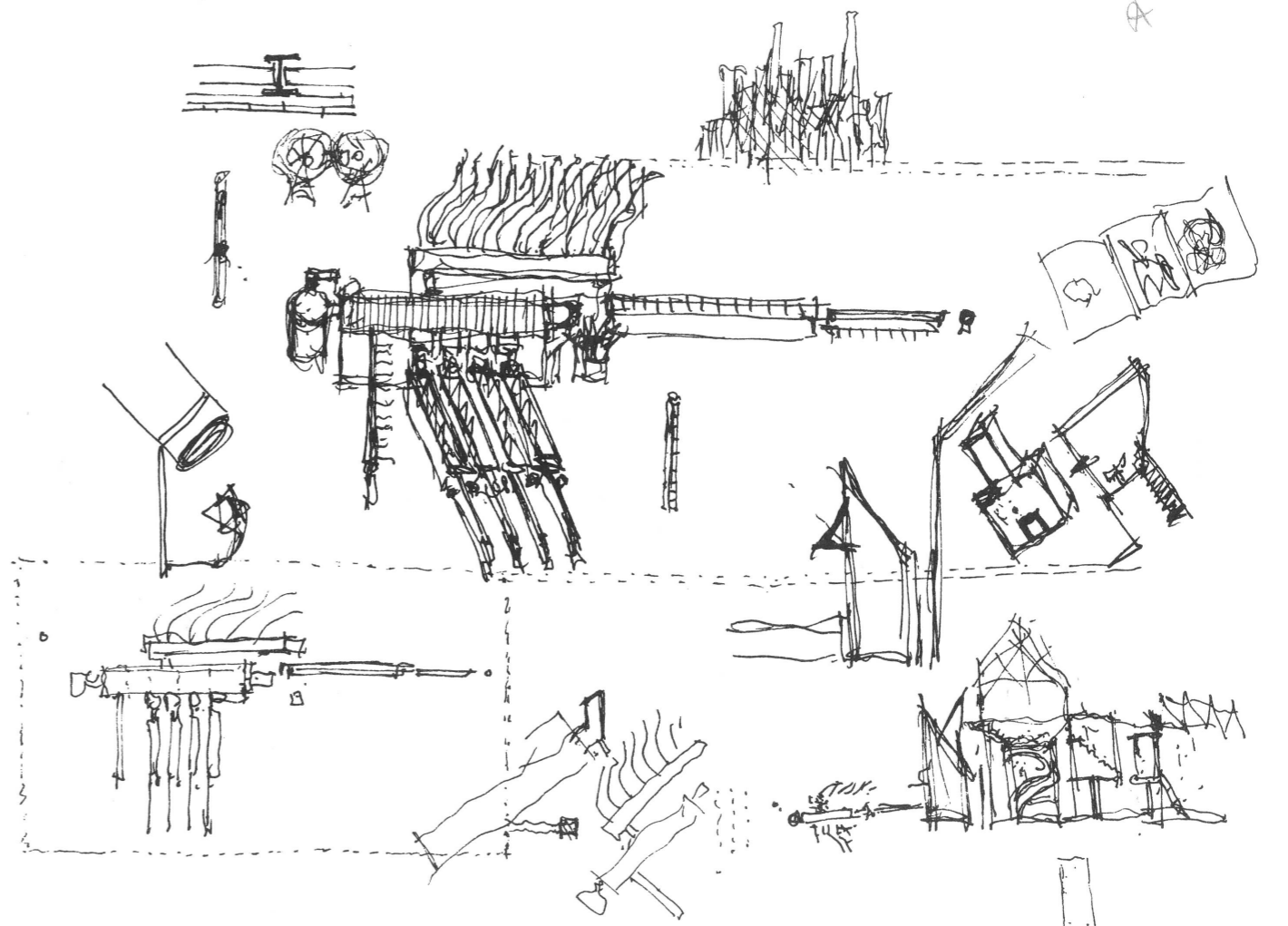

Planning of the trees

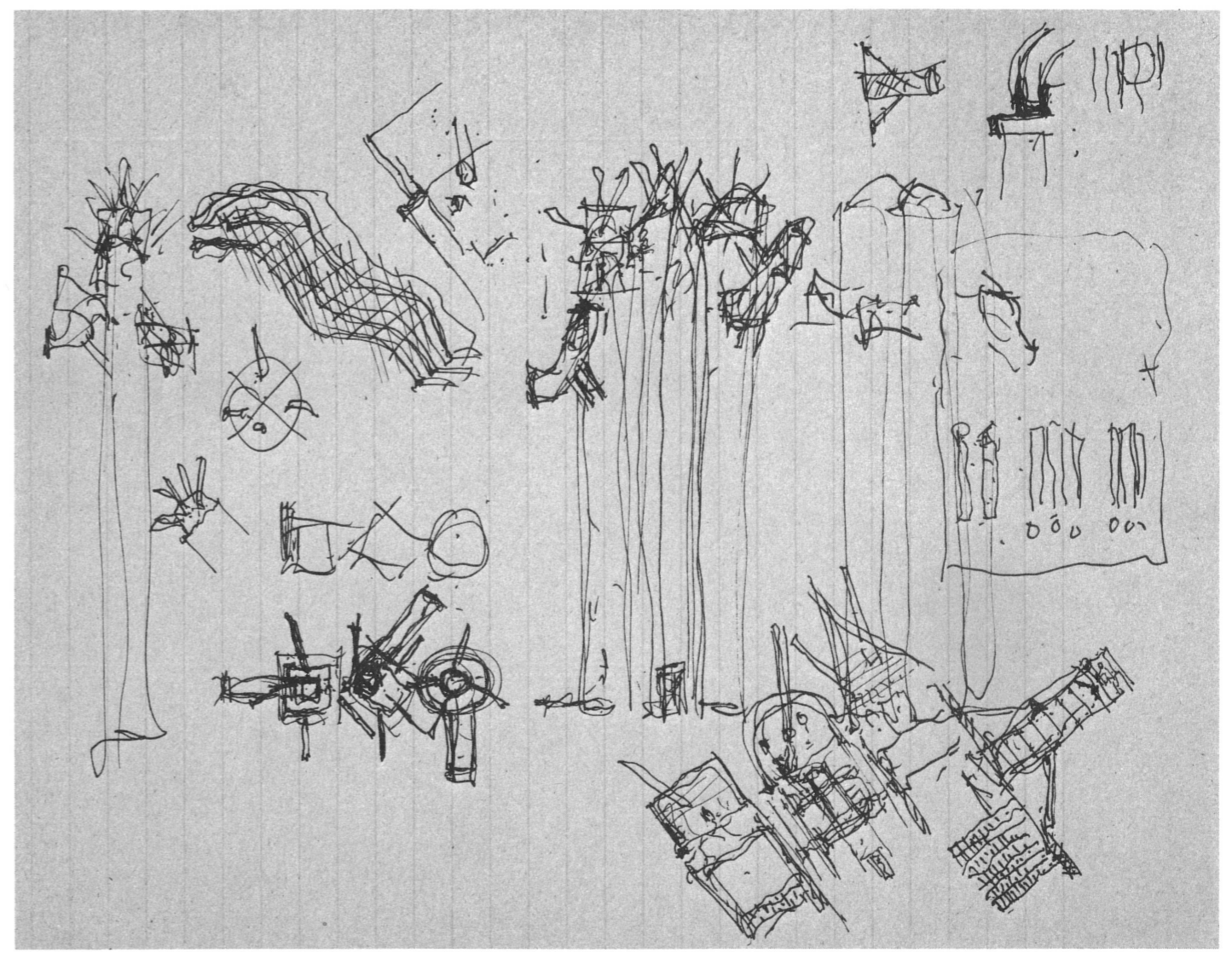
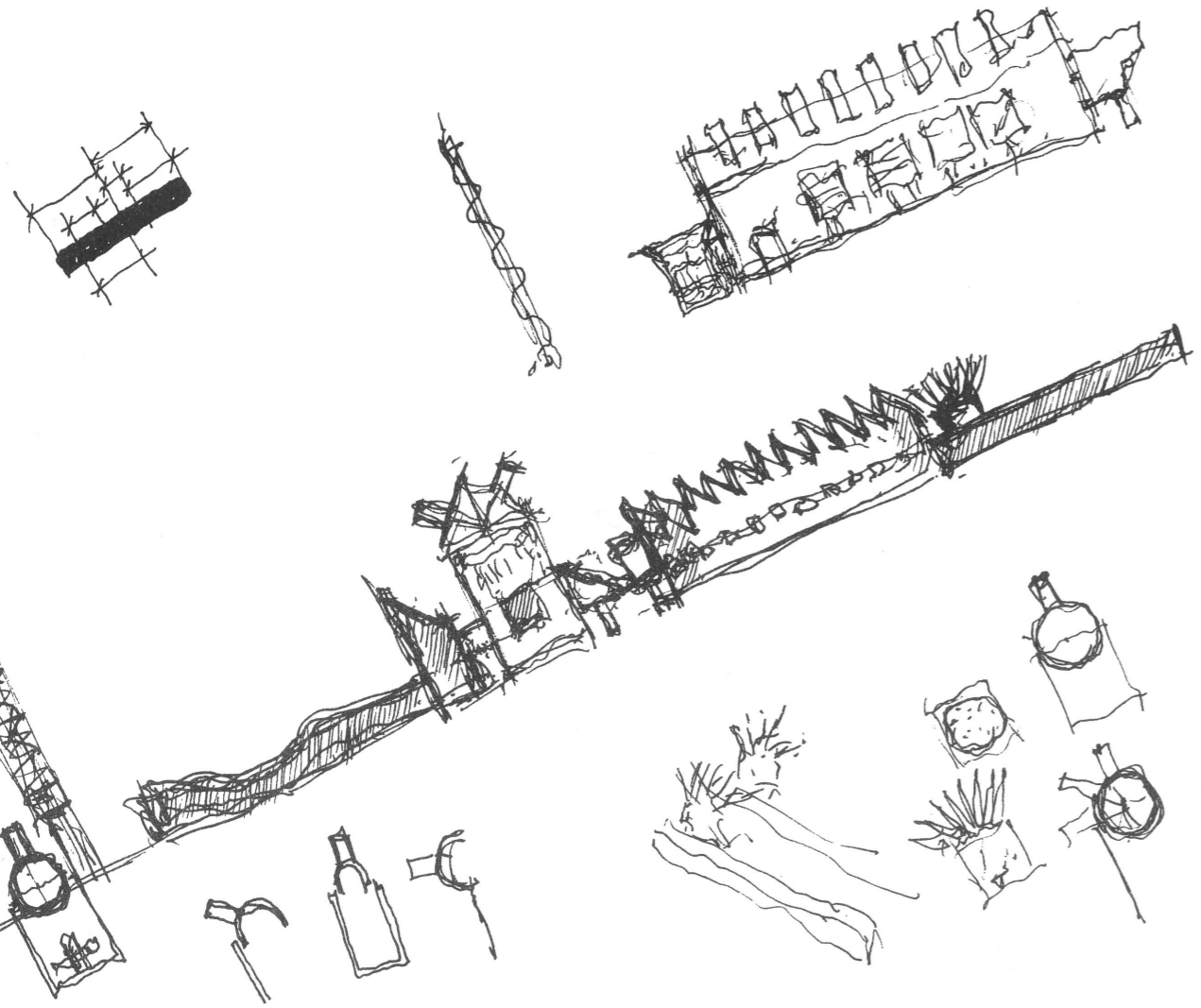
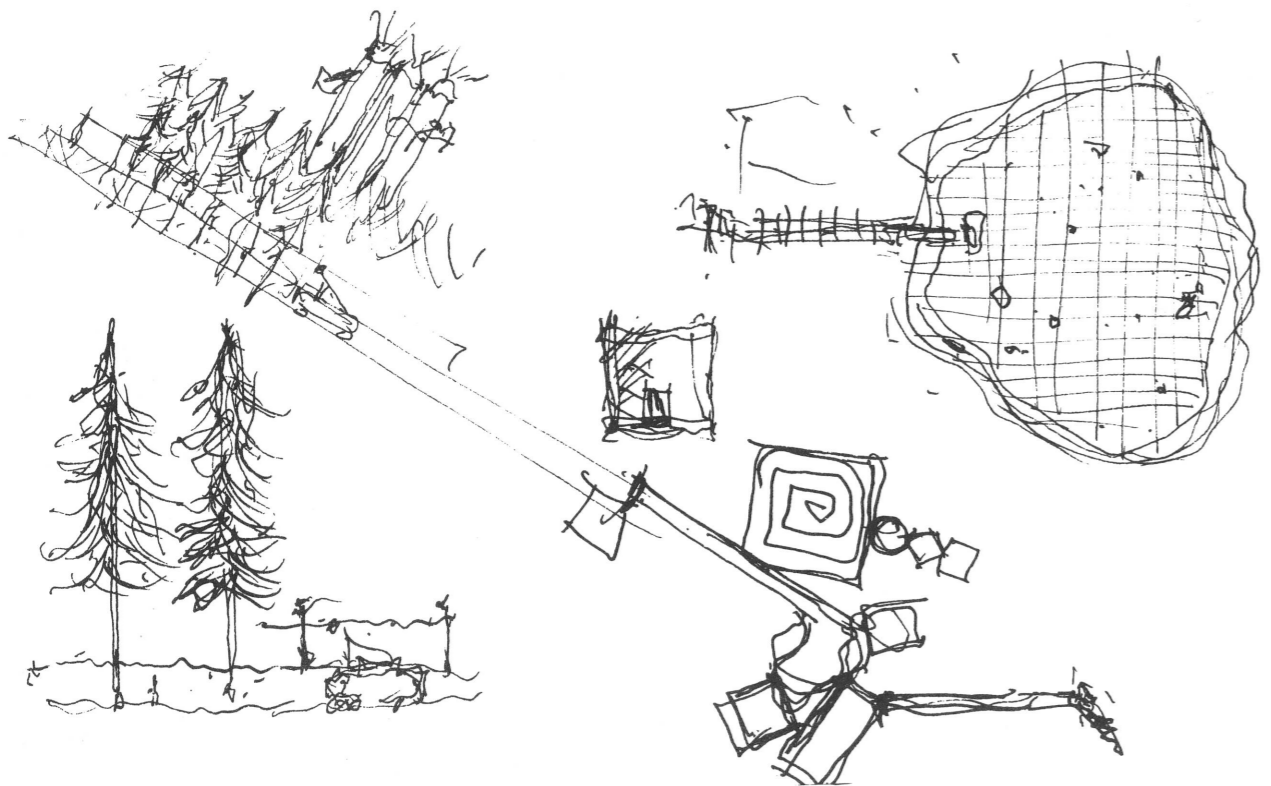



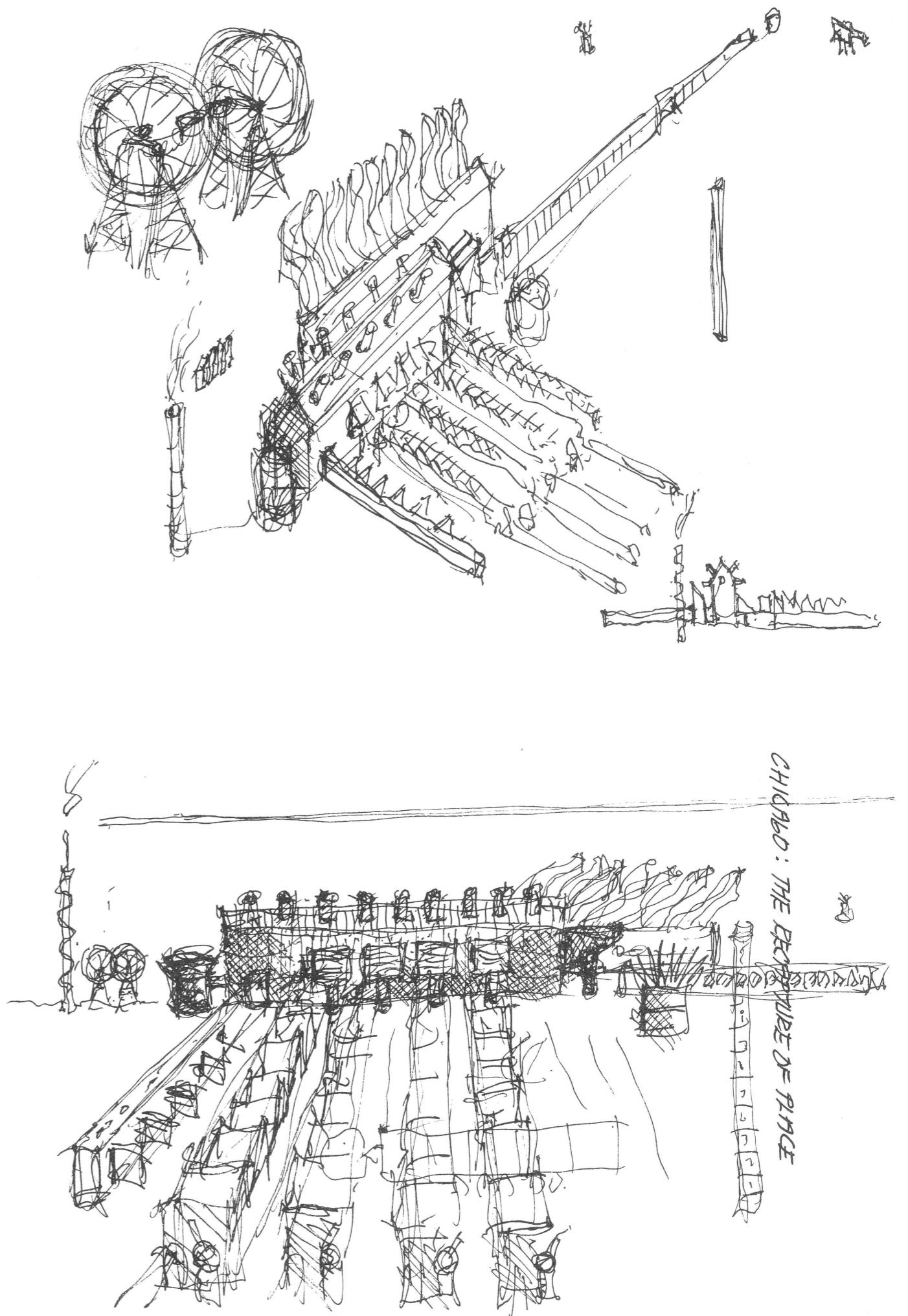
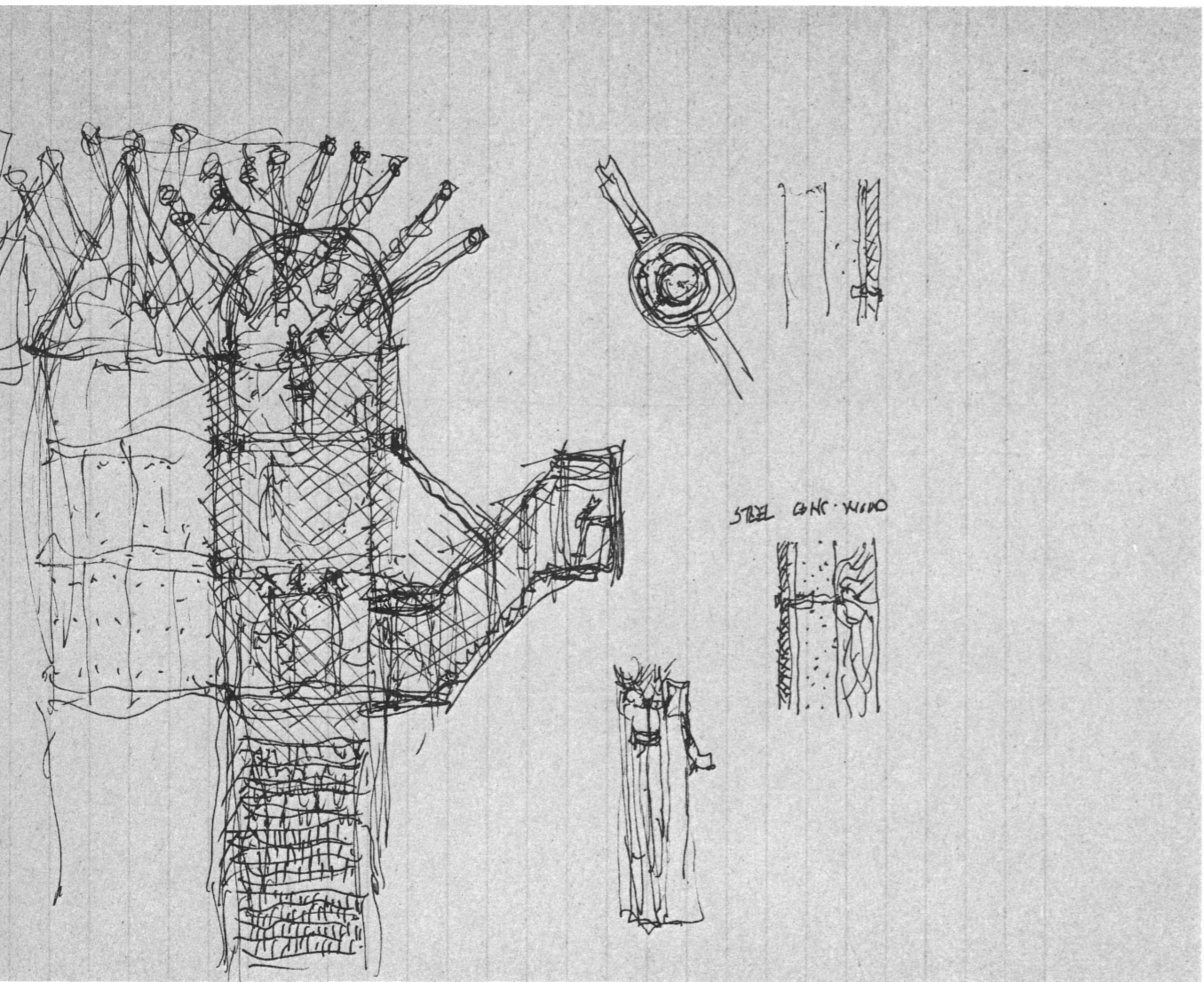

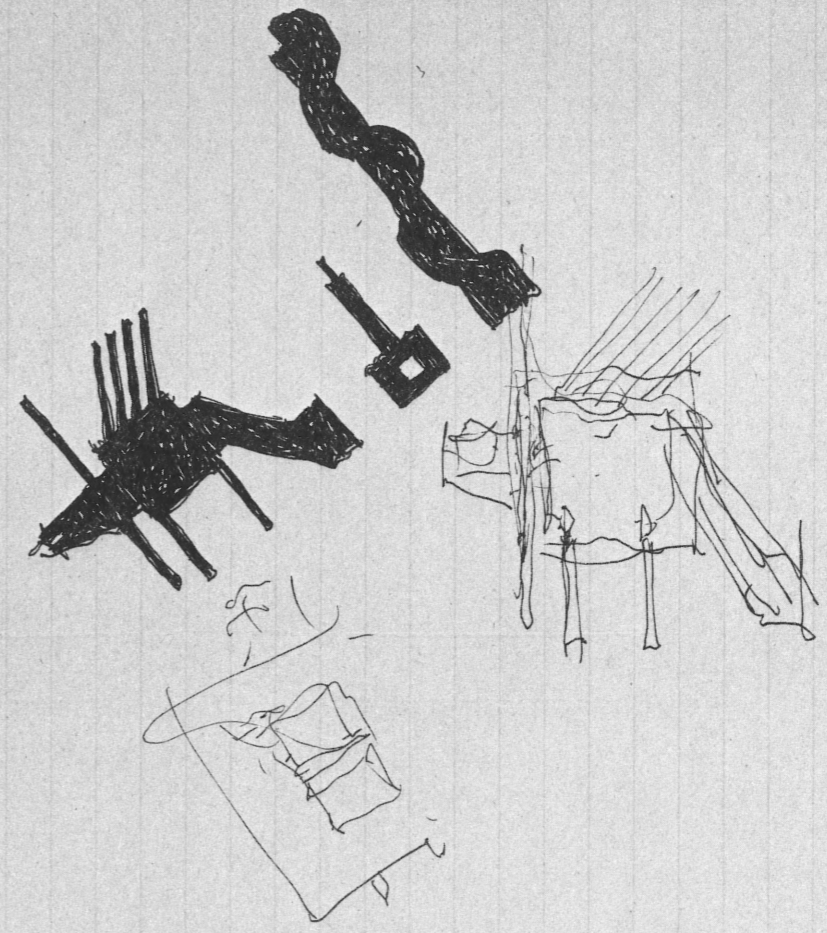
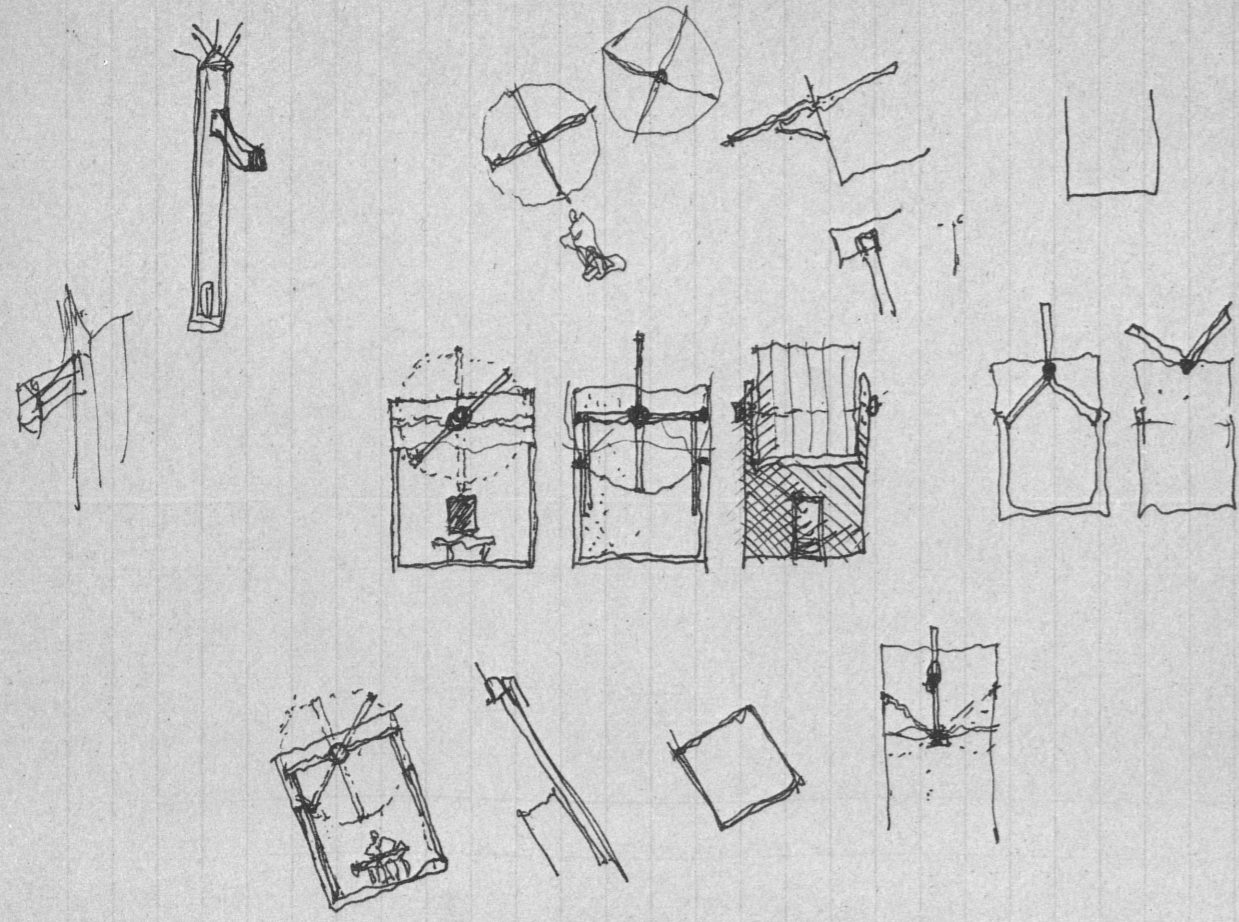

Several sketches  
on one page

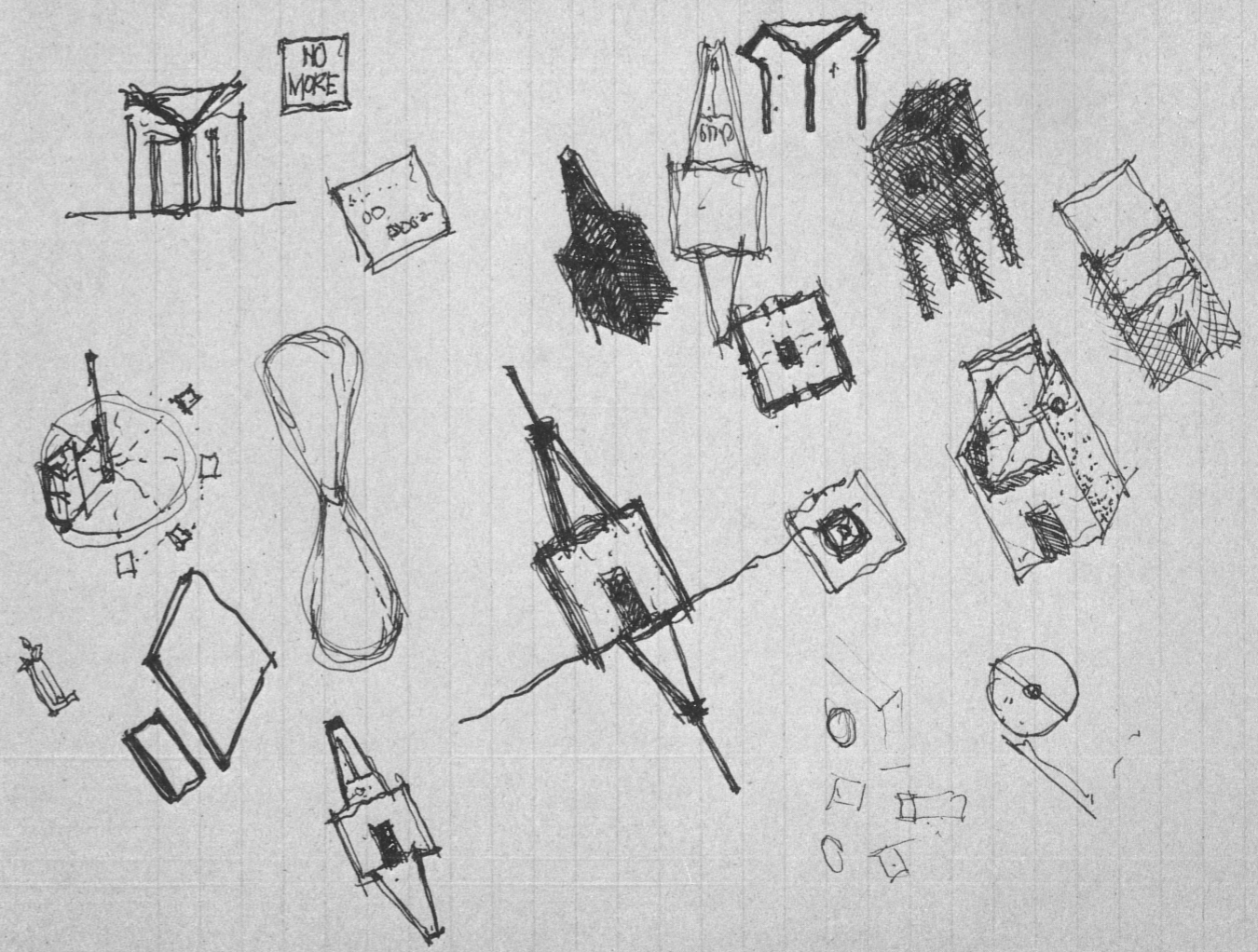
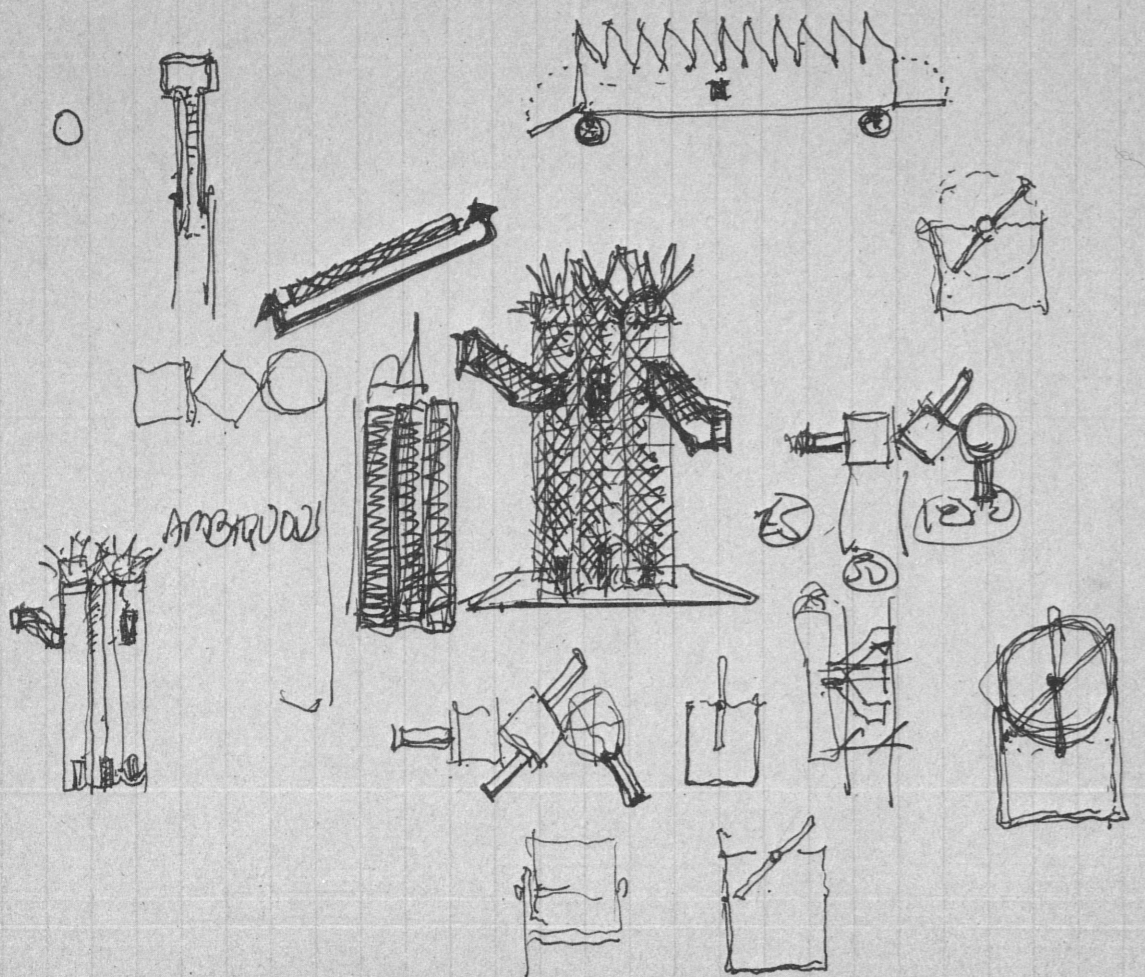

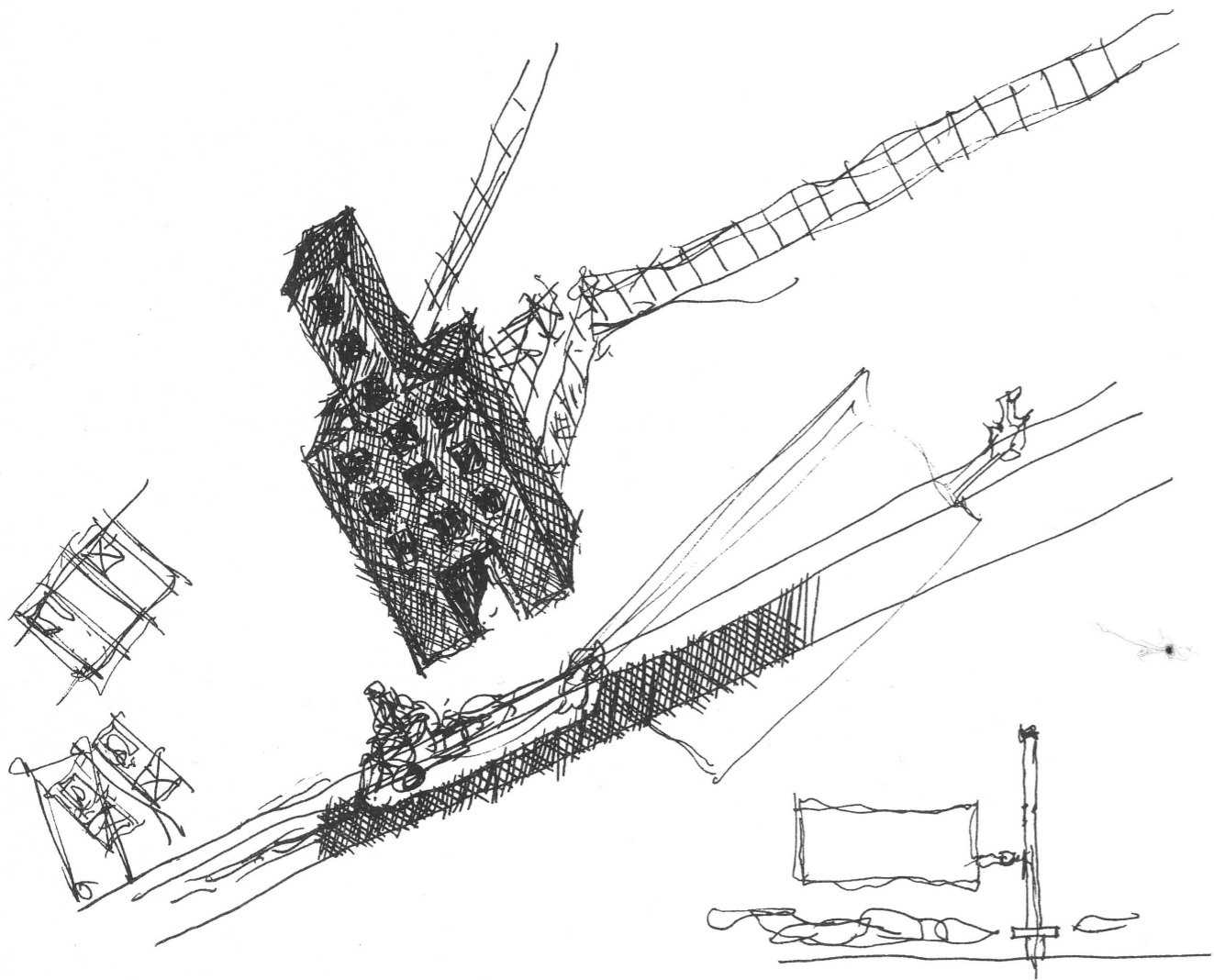

\* the four lines suggest uncertainty. ↓

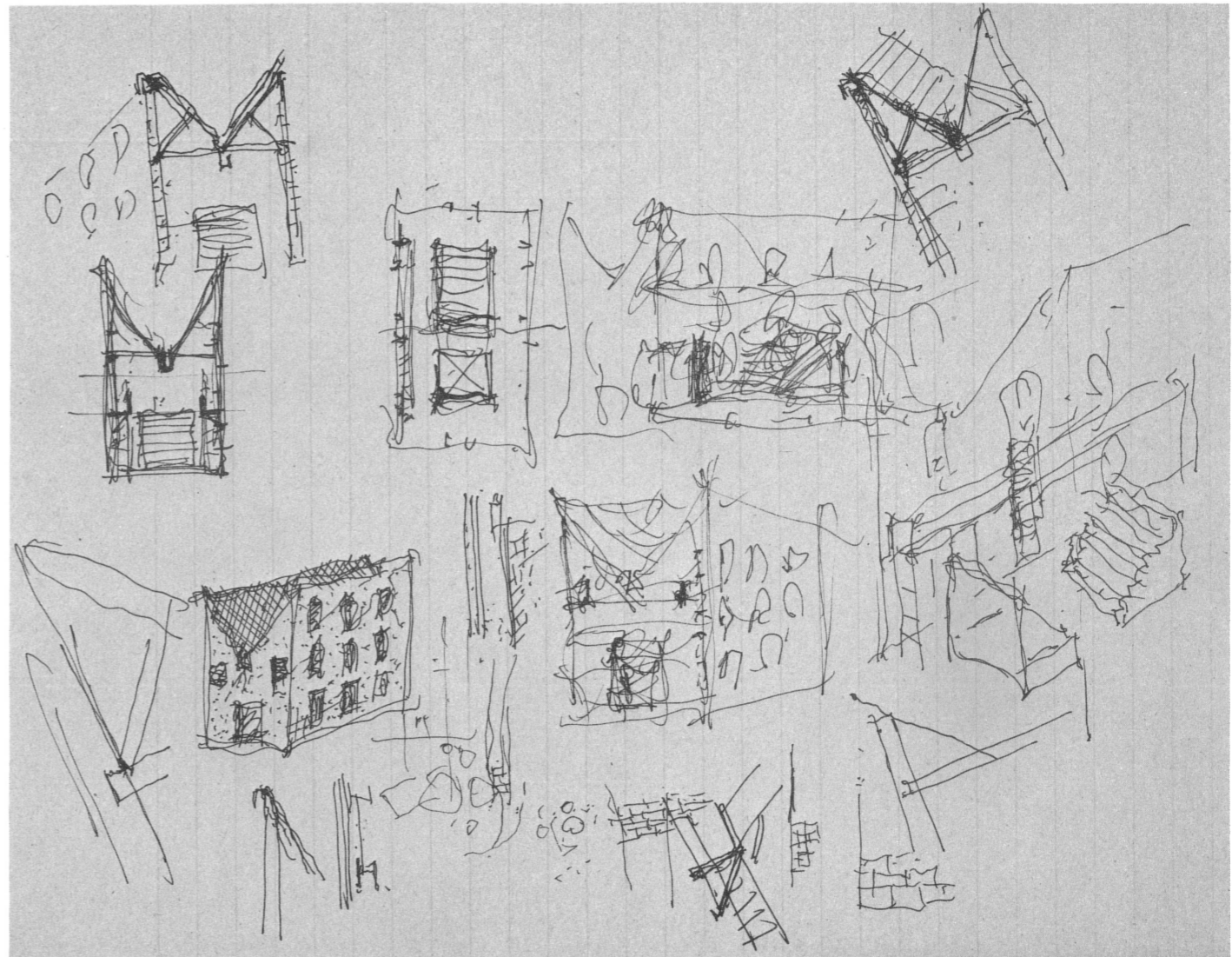

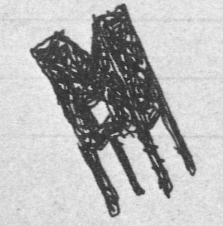
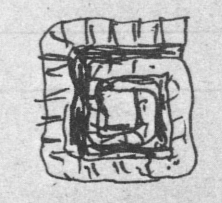
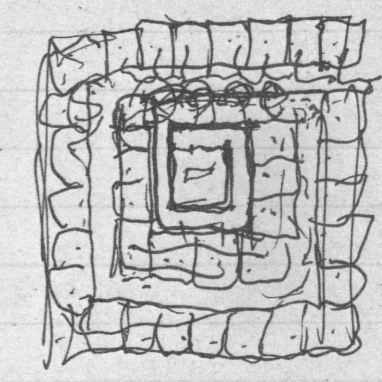
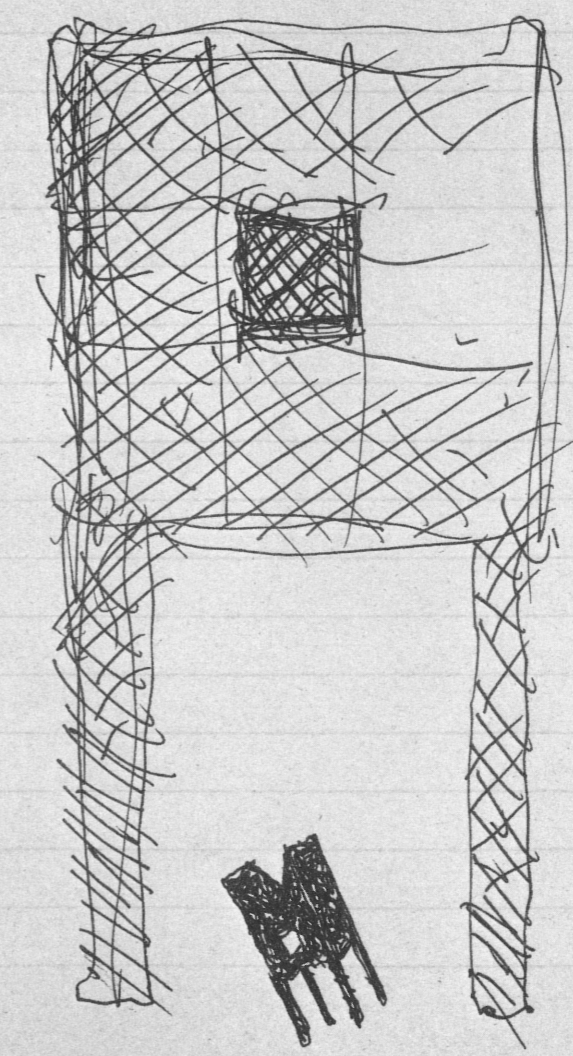
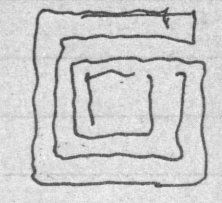
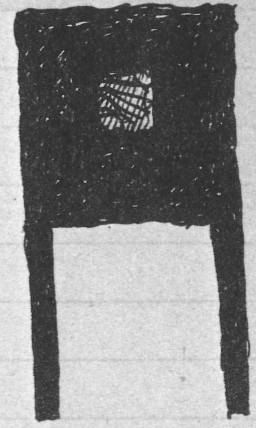
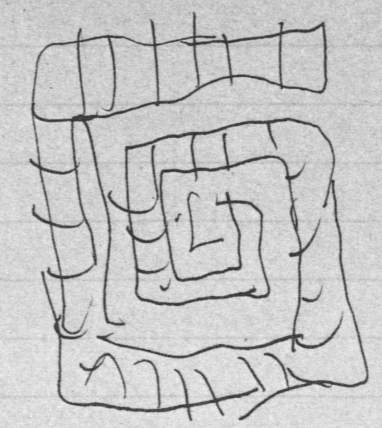
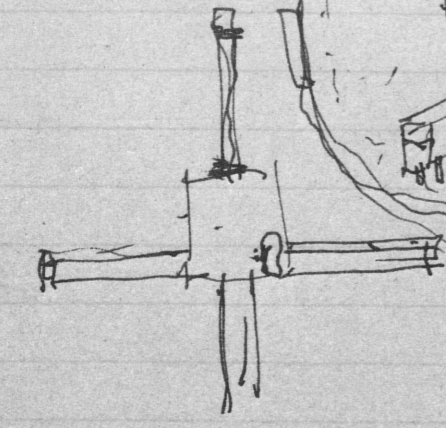
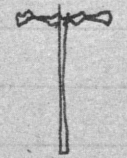
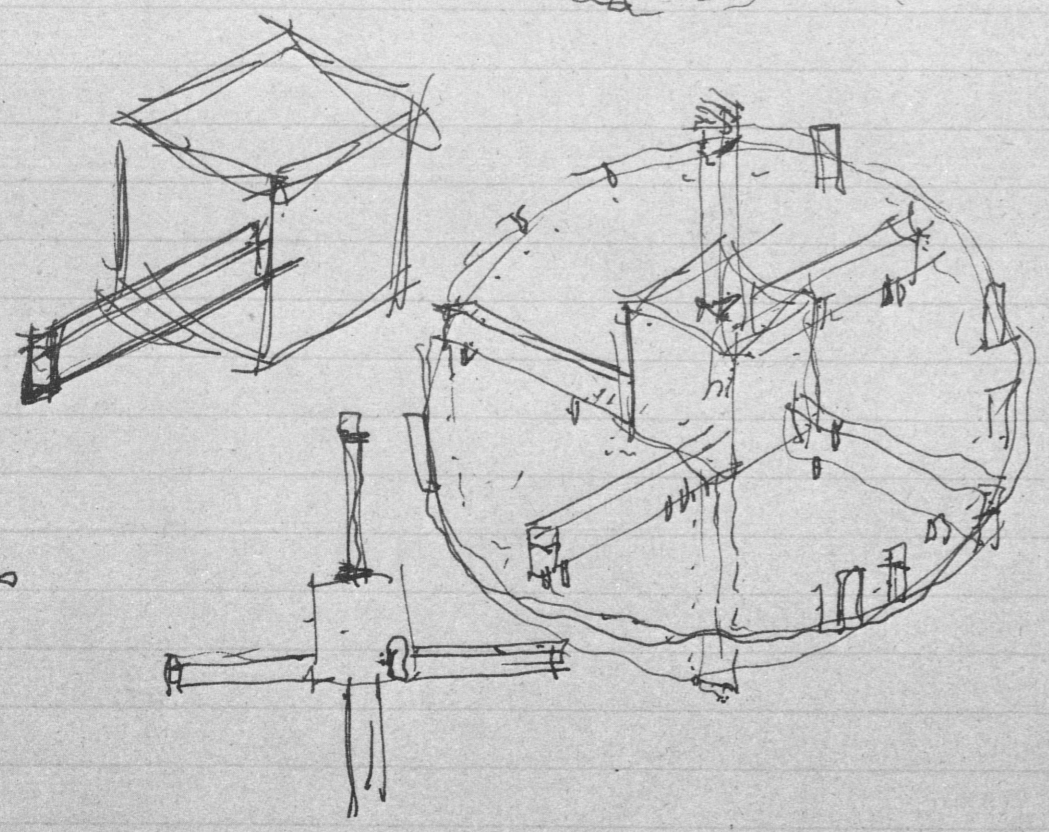
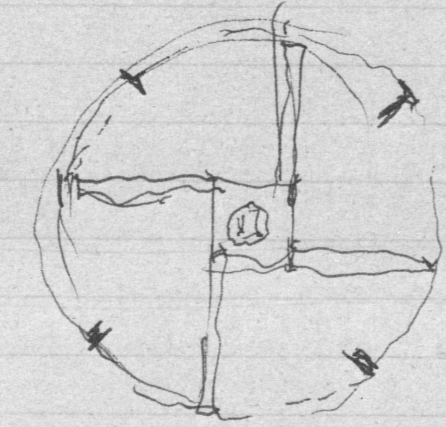
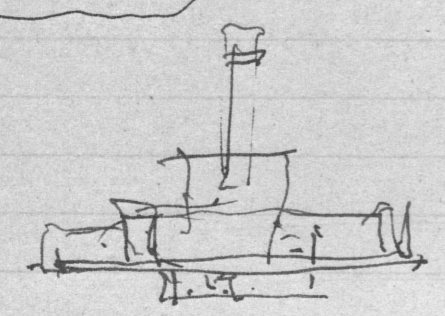
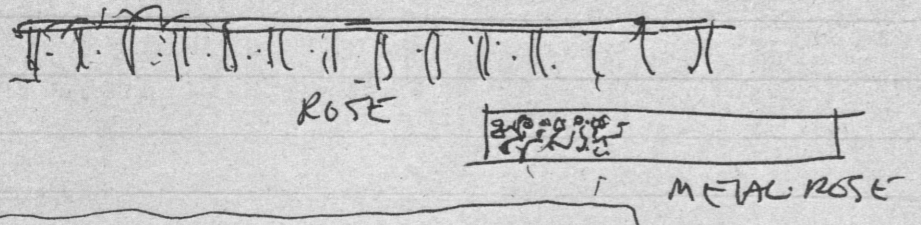
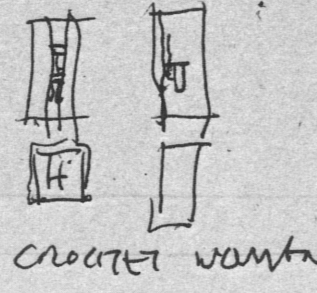
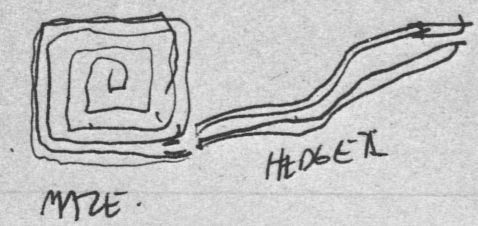
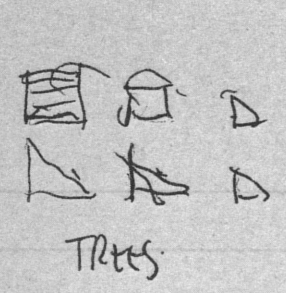

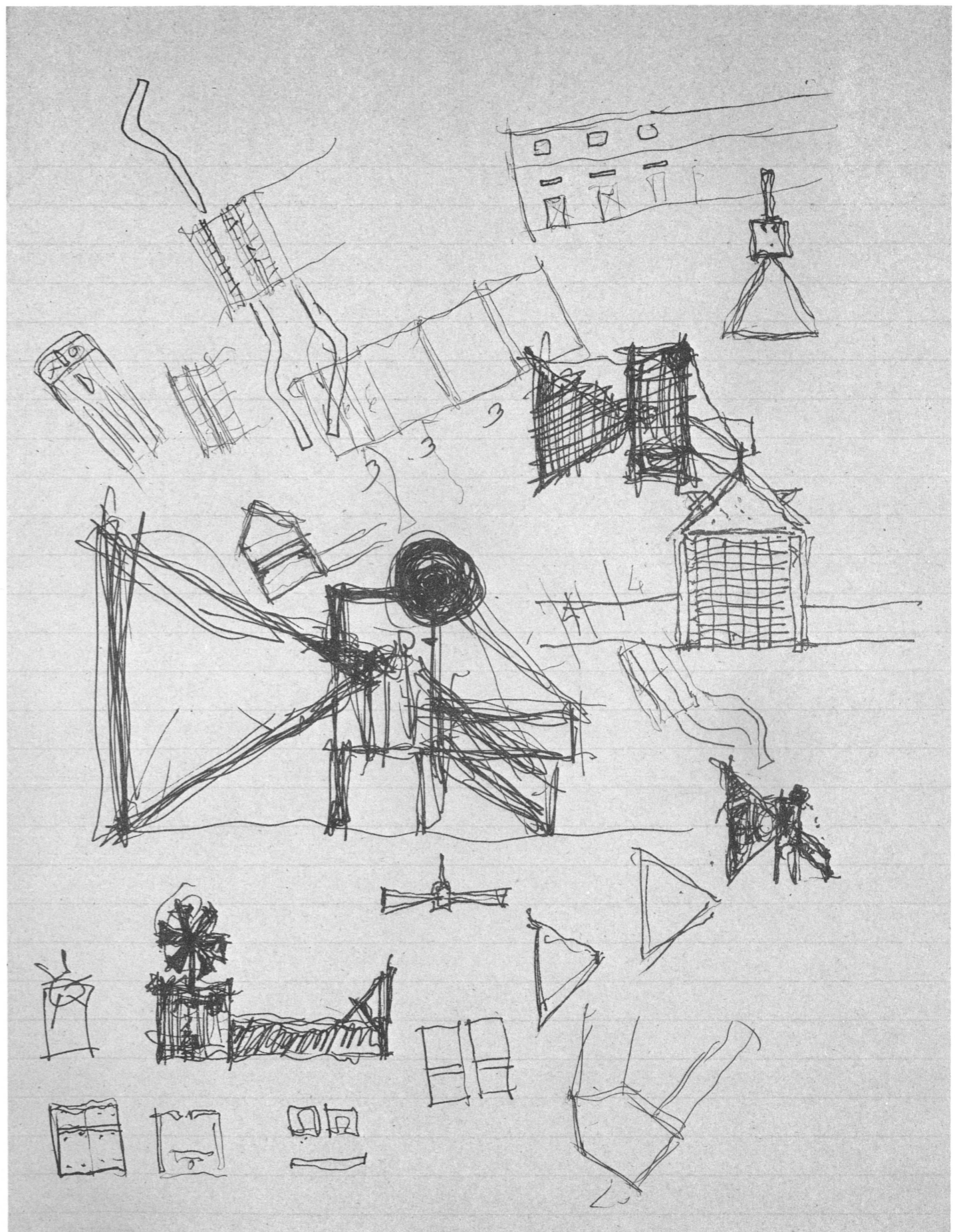
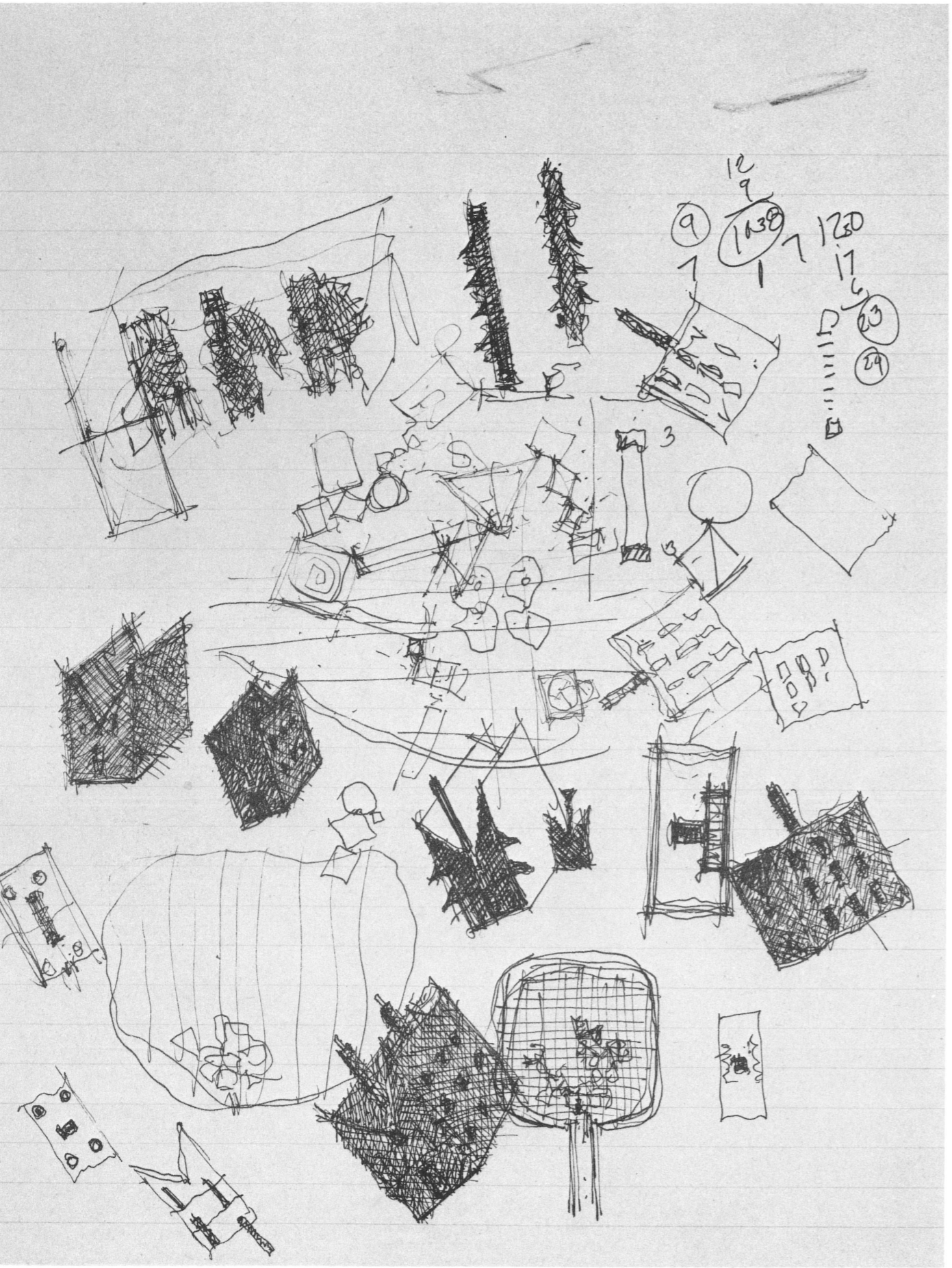

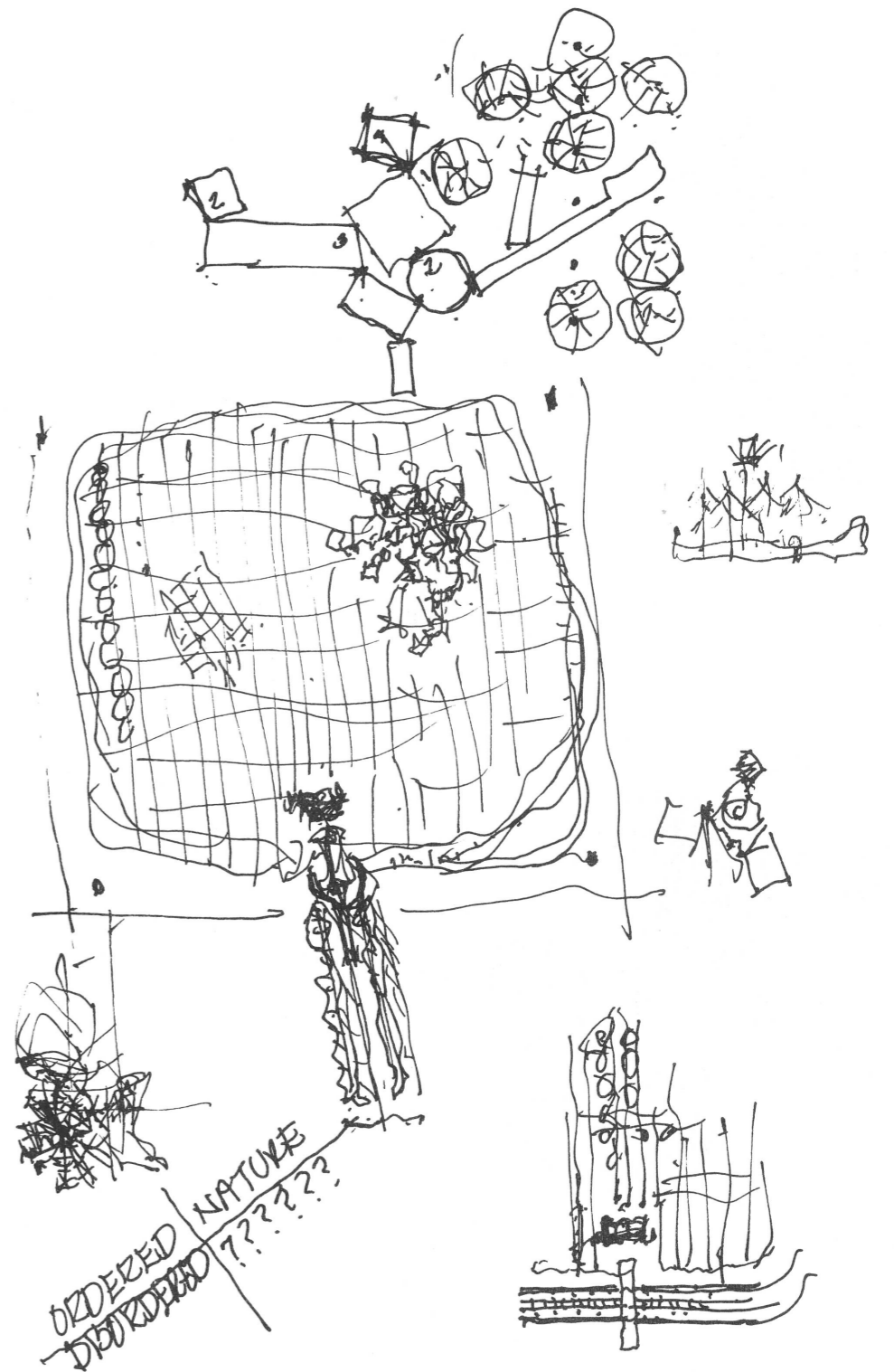
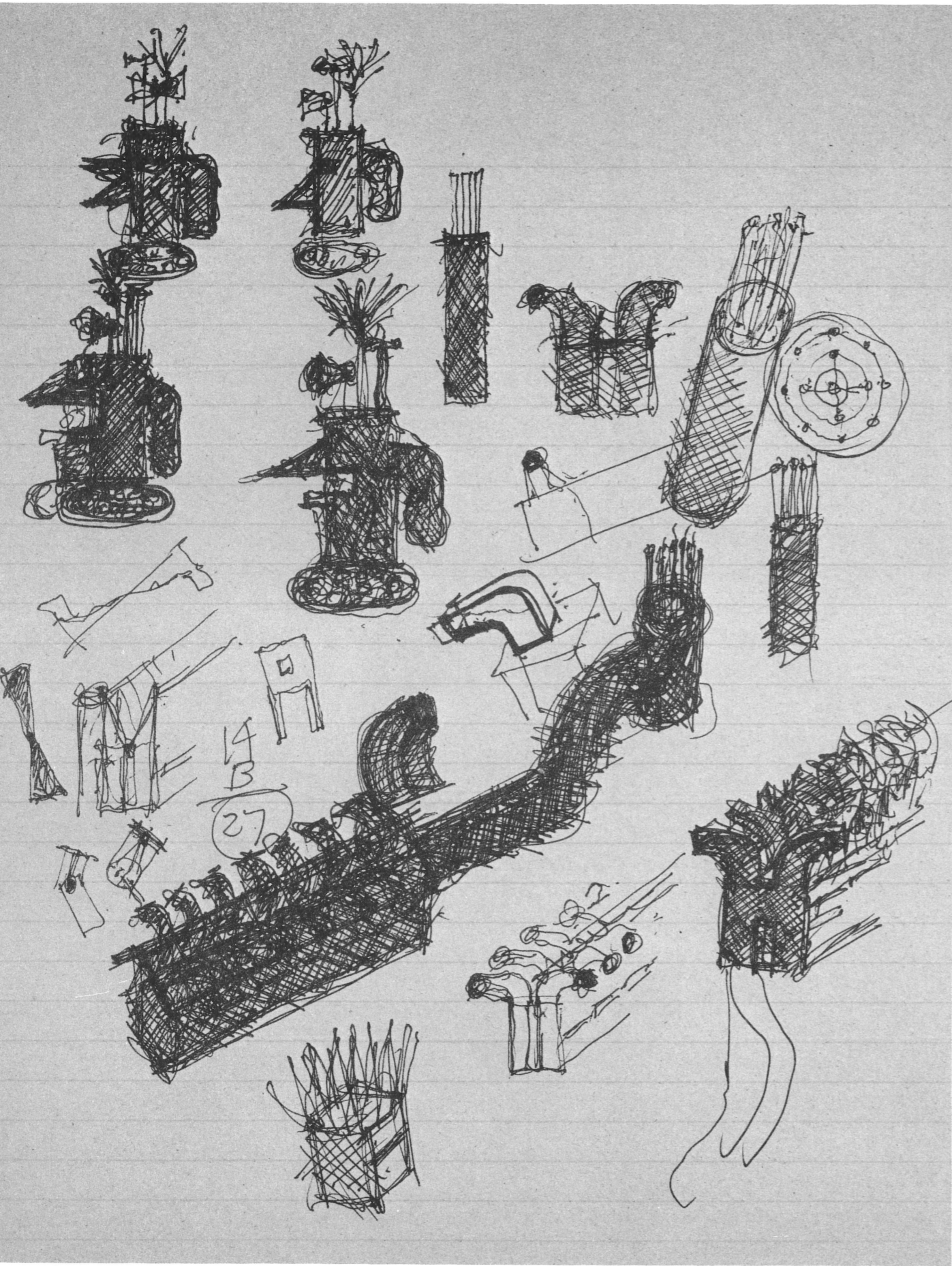

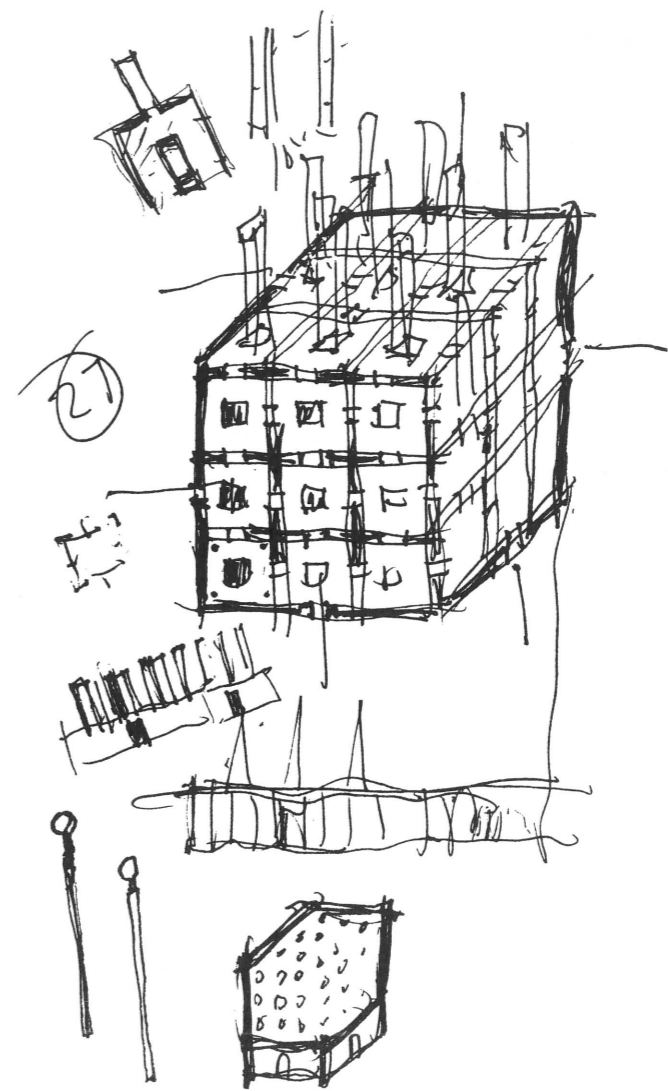
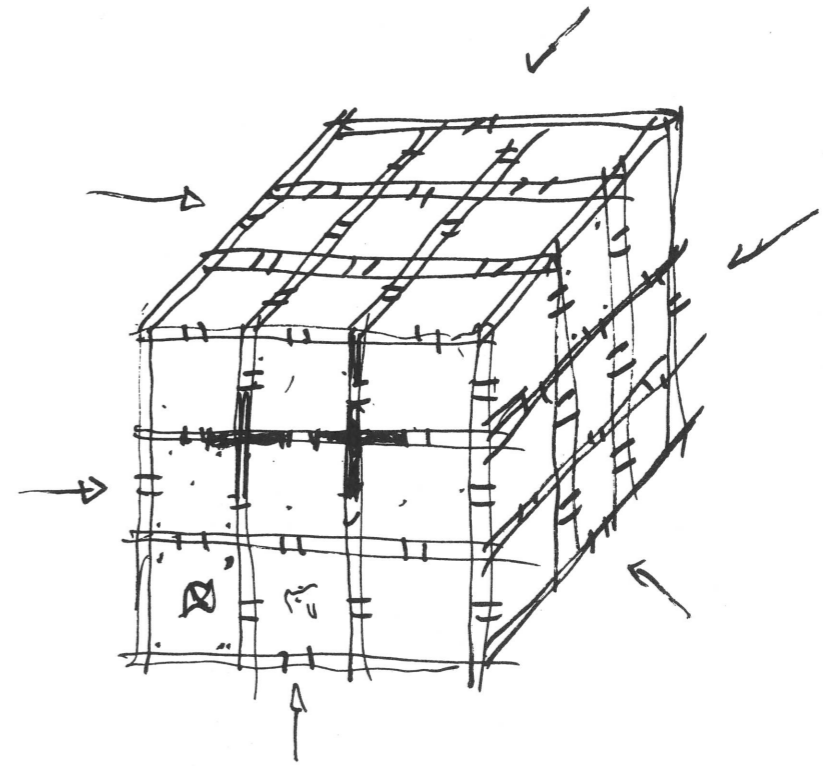
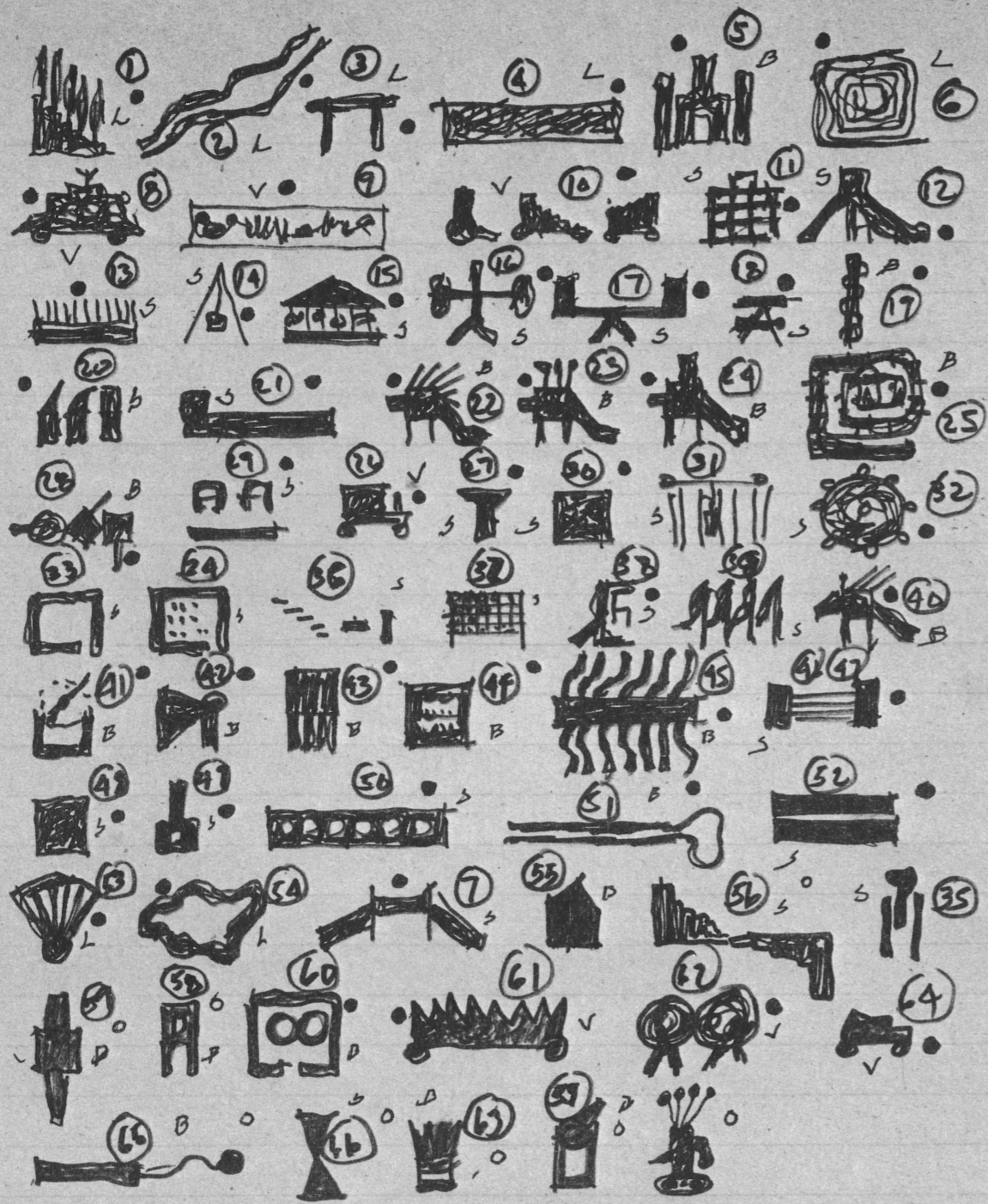





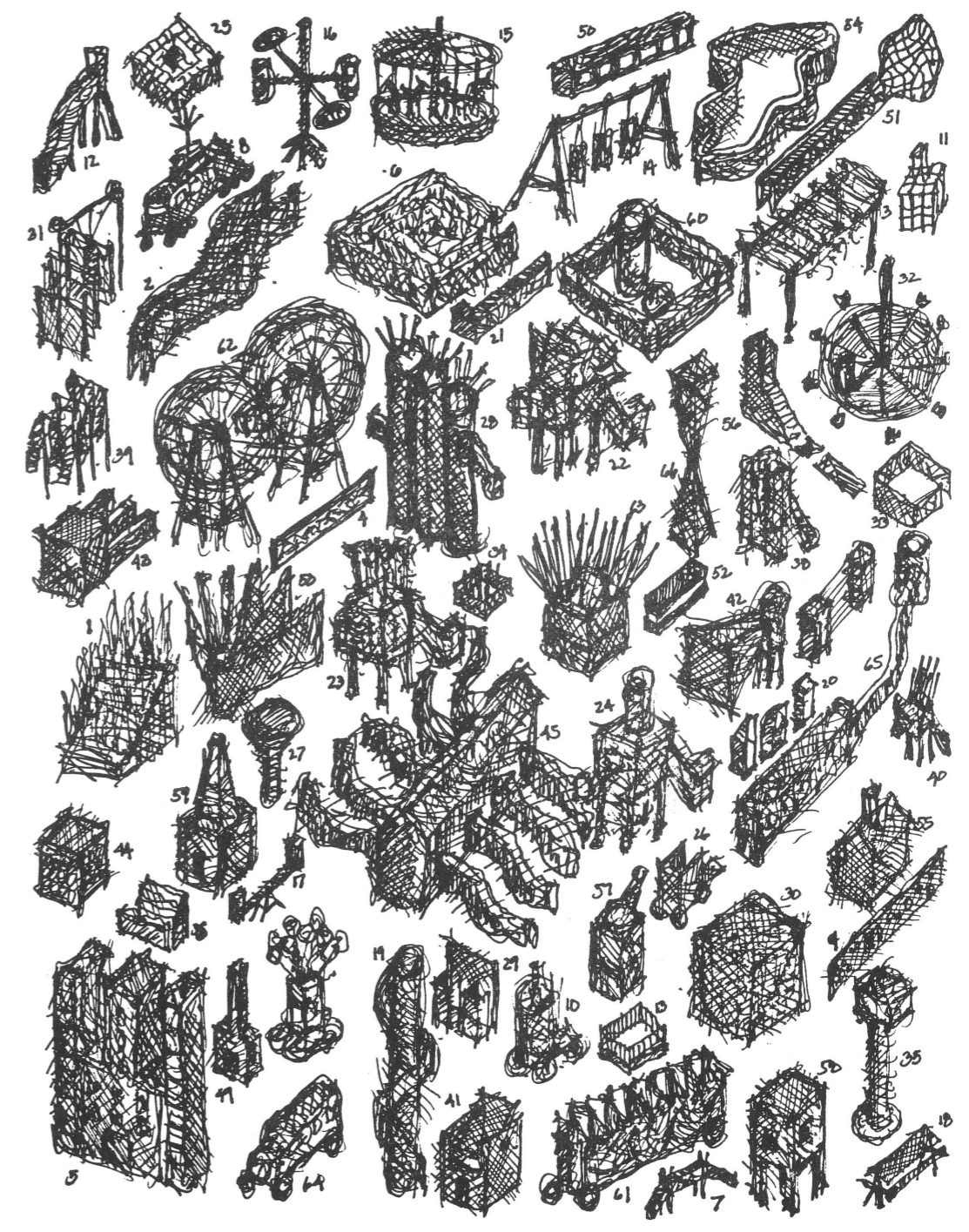
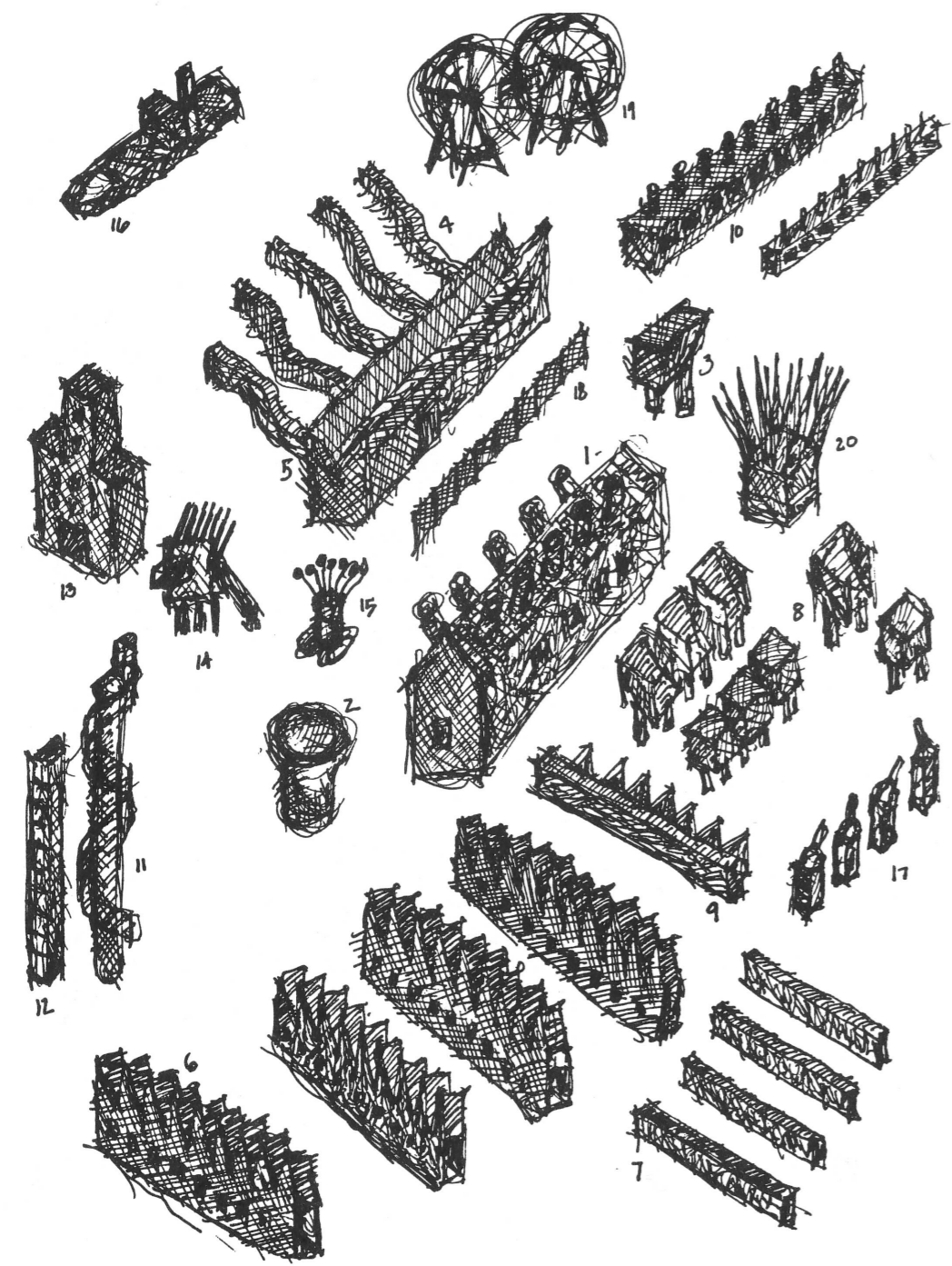

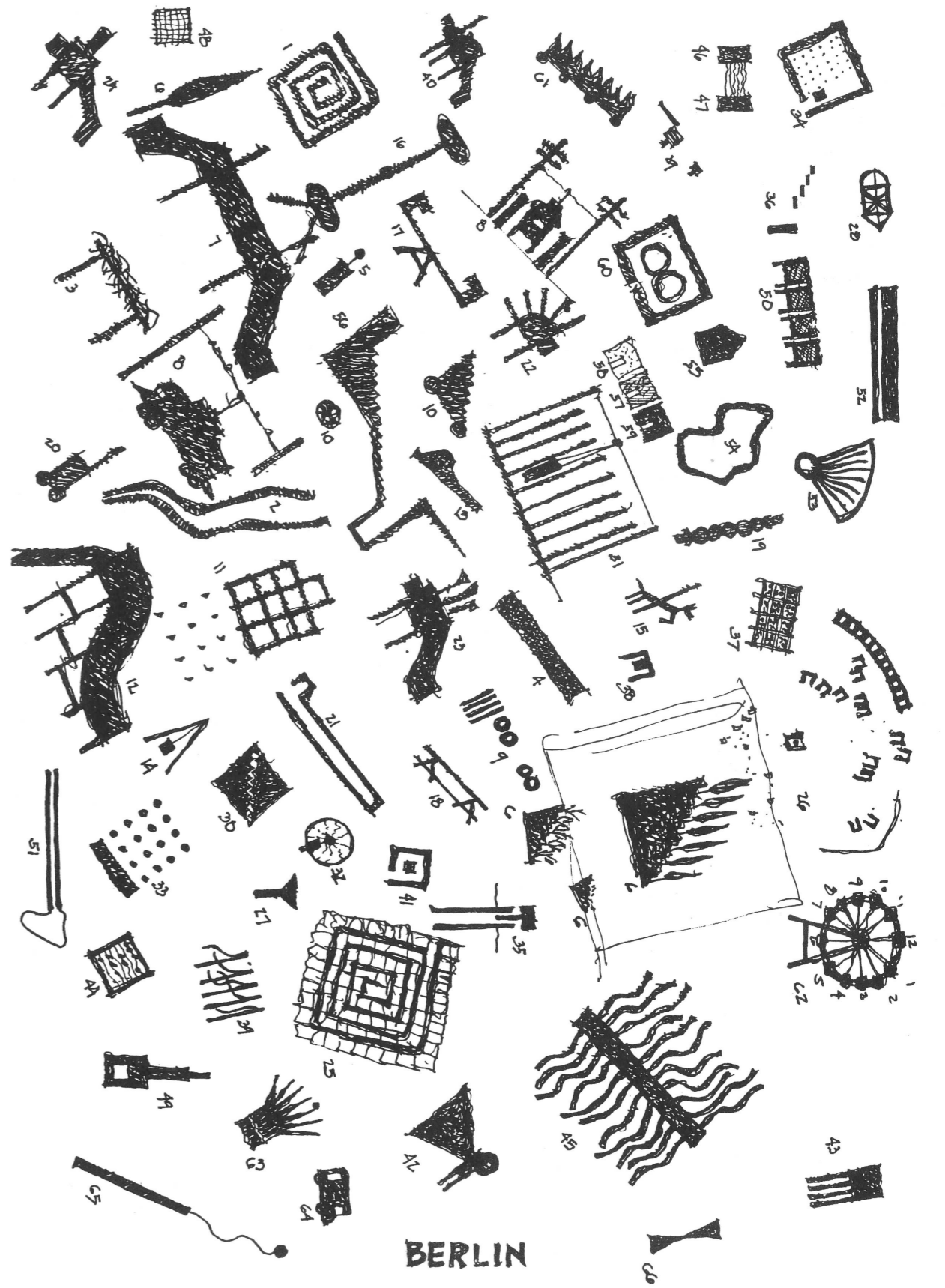
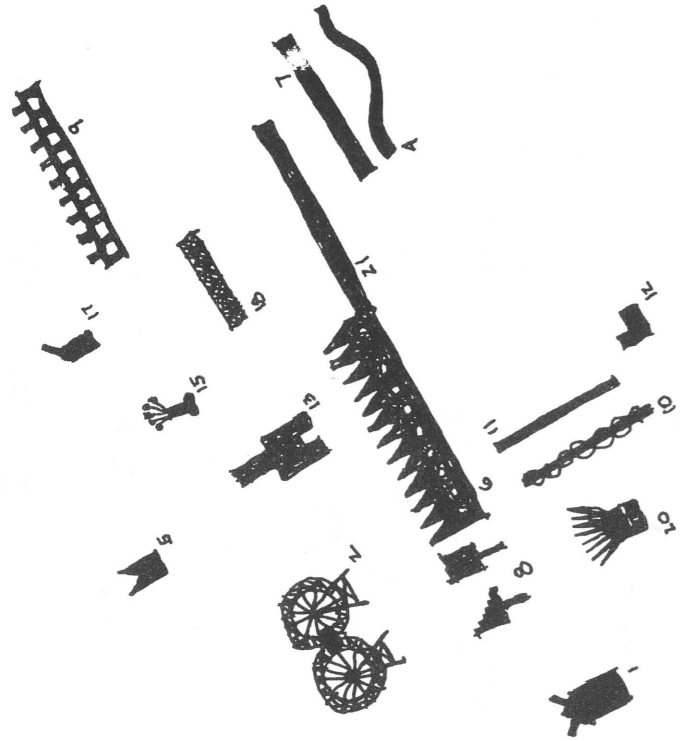

END

TEXT · 1

John Hejduk's *VICTIMS* is the first in a series from AA Publications designed to bridge the gap between the plethora of currently available publications devoted to the illustration of built works and projects, and the ideas - however painfully derived - which have inspired them and others.

Active contributors to the international architectural scene and to the AA's artistic and cultural life have been invited to publish extended texts, collections of essays in the development of a position, commentaries and critical overviews.

Amongst other *Texts* to be published in the series are those of Bernard Tschumi, Peter Eisenman, Daniel Libeskind, Dalibor Vesely and Peter Cook.

LIBRARY AND INFORMATION SERVICE  
POLYTECHNIC OF NORTH LONDON  
HOLLOWAY ROAD  
LONDON N7 8DB

This publication, the accompanying exhibition and the construction of the monument 'The Collapse of Time' in Bedford Square - opposite the Members' Room - have been organised at the Architectural Association, London, through the office of the Chairman, Alvin Boyarsky, assisted by Micki Hawkes, during the period 24 September-25 October 1986.

Lorraine Wild has designed the publication, which has been produced for AA Publications by the AA Print Studio, co-ordinated by Gill Sternbach and assisted by Rob Polley, Annelies Siero and Marilyn Sparrow.  
Production Editor: Vicky Wilson. Technical Co-ordinator: Dennis Crompton.  
Exhibition Mounting Supervisor: Colleen Haley. Pages 41-70 have been re-drawn for publication and exhibition by Nicholas Boyarsky.

The detailed design and construction of 'The Collapse of Time' was undertaken by AA staff members Raoul Bunschoten, Peter Salter and Donald Bates, assisted by Michael Rae, Thomas Cheng, Eyal Bleiweiss, Edna Tanning, Sze Hwei Liew (all students in the School) and the AA Workshop and Maintenance staff.  
Structural Consultant: Frank Newby, Felix J. Samuely & Partners.

Copyright © 1986 John Hejduk and  
the Architectural Association,  
ISBN 0 904503 77 1  
Printed by Spin Offset  
Hand-bound by Collis Bird and Withey

The Architectural Association, 34-36 Bedford Square, London WC1 3ES